



City of Meriden

Purchasing Department

Invitation to Bid

For

Sherman School HVAC System

B024-67

Bids Due: June 27, 2024 @ 11:00 AM

Purchasing Department

142 East Main Street, Room 210

Meriden, CT 06450

(203) 630-4115

**CITY OF MERIDEN BOARD OF EDUCATION
ROGER SHERMAN ELEMENTARY SCHOOL
FIRST FLOOR NEW AIR CONDITIONING SYSTEM
MERIDEN, CONNECTICUT**

SECTION 00010

TABLE OF CONTENTS

GENERAL

00000	Cover
00010	Table of Contents
00020	List of Drawings

DIVISION 0 – BIDDING REQUIREMENTS AND CONTRACT FORMS

LEGAL NOTICE (INVITATION TO BID)
INFORMATION TO BIDDERS
PERMIT FEE SCHEDULE
NON COLLUSIVE BID STATEMENT
BIDDERS QUALIFICATIONS
FORM OF SURETY/BID BOND
PROPOSAL PAGES
PREVAILING WAGE RATES
EJCDC STANDARD FORM OF AGREEMENT
GENERAL CONDITIONS
SUPPLEMENTAL CONDITIONS - INCLUDES INSURANCE REQUIREMENTS AND
PERFORMANCE BOND & LABOR MATERIAL BOND

DIVISION 23 – HVAC

200050	GENERAL CONDITIONS FOR MECHANICAL AND ELECTRICAL SYSTEMS
230548	VIBRATION AND SEISMIC SUPPORTS FOR HVAC PLUMBING AND EQUIPMENT
230700	HVAC INSULATION
232113	PIPING
238119	VARIABLE REFRIGERANT VOLUME DIRECT EXPANSION SYSTEM

DIVISION 26 – ELECTRICAL

260000	GENERAL ELECTRICAL
260500	BASIC ELECTRICAL MATERIALS & METHODS

LIST OF DRAWINGS:

M1.1	1 st FLOOR MECHANICAL PART PLANS
M1.2	MECHANICAL SCHEDULES DETAILS AND PIPING DIAGRAMS
E1.0	BASEMENT PART PLAN, SCHEDULES RISER DIAGRAM AND DETAILS
E1.1	1 st FLOOR POWER PLAN

END OF LIST OF DRAWINGS

LEGAL NOTICE

INVITATION TO BID

The City of Meriden is accepting sealed bids for:

B024-67 – Sherman School HVAC System

The City of Meriden, Board of Education seeks the services of a licensed, certified contractor to furnish labor and materials for Installing a Variable Refrigerant Flow based air conditioning system for the lower level classrooms at Roger Sherman Elementary School. The new equipment will need to interphase seamlessly with the existing Building Management System.

Bids shall be submitted on forms and in the manner specified. Forms and specifications may be obtained from the Purchasing Department, on the City of Meriden website (www.meridenct.gov/business/bids-rfps/), and on the State of Connecticut Department of Administrative Services website (<https://webprocure.proactiscloud.com>). Bids will be accepted at the Purchasing Department, 142 East Main Street, Room 210, Meriden, Connecticut 06450 until **11:00 AM, Local Eastern Standard Time on June 27, 2024** at which time they will be publicly opened and read. Any bid received after the time and date specified shall not be considered.

There will be a MANDATORY Pre-Bid Conference on Friday, June 7, 2024 at 10:00 AM - Roger Sherman Elementary School, 64 North Pearl St, Meriden, CT 06450.

The right is reserved to reject any or all bids, in whole or in part, to award any item, group of items, or total bid, and to waive informality or technical defects, if it is deemed to be in the best interest of the City of Meriden. No bidder may withdraw its bid within sixty (60) days of the date of the bid opening.

Each bid shall be accompanied by a Certified Check or Bid Bond in the amount of Ten (10%) percent of the amount bid.

Labor and Material Payment Bond and a Performance bond for One Hundred Percent (100%) of the contract price, with a corporate surety approved by the City of Meriden, will be required of the lowest responsible bidder.

The attention of bidders is call to the requirement for minimum wage rates to be paid under this contract.

The City of Meriden is an Affirmative Action/Equal Opportunity Employer. Disadvantaged, minority, small, and women business enterprises are encouraged to respond.

Rawle Dummett
Purchasing Officer
City of Meriden, CT 06450-8022
Dated: May 24, 2024

CITY OF MERIDEN, CONNECTICUT

B024-67 – Sherman School HVAC System

INFORMATION TO BIDDERS

1. BIDDING PROCEDURES

Sealed Bids shall be submitted on the forms designated by the attached proposal bid forms. Bids will be received by the City of Meriden’s Purchasing Department, Room 210, City Hall, 142 East Main Street, Meriden, Connecticut, 06450-8022 until 11:00 AM on June 27, 2024 and thereafter immediately read in public (the “bid opening”).

2. BIDS

Bids are to be submitted on the attached proposal forms. Please submit two paper copies of the proposal forms and Bidder’s Qualification Statement. One shall be an original and one can be a copy. **One complete copy of your bid must be submitted on a flash drive.**

BID WILL BE AUTOMATICALLY REJECTED FOR ANYONE SUBMITTING A SURETY OTHER THAN THOSE SPECIFIED.

- a. Bids must be made out and signed in the corporate, or other, name of Bidder, and must be fully and properly executed by an authorized person.
- b. The sealed envelope must denote the Bidder’s name and address in the upper left hand corner and the words “BID DOCUMENT B024-67 – Sherman School HVAC System to be opened at 11:00 AM” in the lower left hand corner.
- c. Bids received later than the time and date specified will not be considered.
- d. Amendments to or withdrawal of bids received later than the date and time set forth in the bid opening will not be considered.
- e. All prices must be in ink or typewritten. In the event of a bidder’s mathematical error in tabulating any bid prices, *the written unit prices shall govern.*

3. BIDDER QUALIFICATIONS

Bidders will be required to fill out, and include as part of its bid, any attached Bidder’s Qualification Statement.

In determining the qualifications of a bidder, the City of Meriden will consider the bidder’s record of performance in any prior contracts for construction work. The City of Meriden expressly reserves the right to reject a bid if the bidder’s historical performance, in the sole opinion of the City of Meriden, has been unsatisfactory in any manner or if the bidder has habitually and without just cause neglected the payment of bills or has otherwise disregarded its obligations to subcontractors, suppliers, or employees.

4. EXAMINATION OF BIDDING DOCUMENTS

Bidders are to examine all documents and visit the site in order to make a thorough examination of the conditions so that the bidder may familiarize itself with all of the existing requirements, conditions, and difficulties that will affect the execution of the work in order to determine the amount of work necessary to carry out the true intent of the specifications and work shown on the drawings.

The City of Meriden and its agents do not have any responsibility for the accuracy, completeness, or sufficiency of any bid document obtained from any other source other than from the City of Meriden. Obtaining documents from any other source(s) may result in obtaining incomplete and inaccurate information. Obtaining documents from any other source may also result in failure to receive any addenda, corrections, or other revisions to the documents that may be issued.

No request shall be honored if such request is made less than seven (7) calendar days prior to the date fixed for the opening of bids. Any and all such interpretations, and any supplementary instructions, will be in the form of a written addenda to the specifications which, if issued, will be made available on the City of Meriden website (www.meridenct.gov) unless it is to change the date fixed for the opening of bids, not later than three (3) days prior to the date fixed for the opening of bids. Bidders are encouraged to check the website regularly for addenda. Failure of any bidder to receive any such addenda shall not relieve any bidder from any obligations under its bid as submitted.

Any questions about the bid document must be submitted in writing via email to meridenpurchasing@meridenct.gov. Any other format of question will not be answered.

5. BIDS TO REMAIN OPEN

No bidder may withdraw its bid within sixty (60) days of the date of the bid opening. Should there be reason why the contract cannot be awarded within the specified period, the time may be extended by mutual agreement between the City of Meriden and the successful bidder.

6. AWARD OF CONTRACT

The Purchasing Officer reserves the right to make an award on the bid which, by the Purchasing Officer's judgment and recommendation from the Department of Public Works/Engineering following bid evaluations, best meets the specifications and is deemed to be in the best interest of the City of Meriden.

The contract will not be awarded to any corporation, firm, or individual which/who is in arrears to the City of Meriden by debt or contract, or who is in default as security or otherwise by any obligation to the City of Meriden.

The right is reserved to reject any or all bids, in whole or in part, to award any item, group of items, or total bid, and to waive informality or technical defects, if it is deemed to be in the best interest of the City of Meriden.

7. BID PROTEST PROCEDURE

In the event that any bidder wishes to protest the potential award of a bid, or any procedure of act in the advertising or soliciting of the bids, said bidder must make said protest in writing, which shall state the reason therefore and request a conference with respect thereto. Said protest must be received in the City Purchasing Office within **FIVE (5)** business days after the delivery of bid results or decisions. A conference with respect to said protest shall be scheduled by the Purchasing Officer forthwith and shall be attended by him or his designee and such other persons as the Purchasing Officer and the City Manager shall require to attend. The subject matter of said conference shall be limited to the reasons for the protest specified in the written request for said conference. Said conference shall also include a discussion of all possibilities for a resolution of dispute. The City shall make a decision in writing within three (3) business days after said conference and forward the same to the protesting bidder forthwith. In the event that any protesting bidder wishes to take legal action against the City, they must fully comply with all of these instructions to bidders.

8. CITY OF MERIDEN, LOCAL PREFERENCE – N/A

9. EXTENSION OF AGREEMENT – N/A

10. TIME

Inasmuch as the contract concerns a public improvement, the provisions of the contract relating to the time of performance and completion of the work are of the essence of the contract. Accordingly, the successful bidder/contractor (“Contractor”) shall begin work on the day specified in paragraph 2.04 of the General Conditions and shall perform the work diligently so as to permit full use not later than the first day following the construction period established in the Contract. See paragraph 10 entitled “Liquidated Damages” of the Agreement between City of Meriden, as owner, and the Contractor.

11. SCHEDULE OF WORK

The Contractor shall schedule all work in a manner that will not disrupt City of Meriden operations. Once the work has begun, the Contractor shall work full-time until completion of the Contract.

12. TAXES

The City of Meriden is exempt under Connecticut General Statutes from the payment of the excise taxes imposed by the federal government and the Sales and Use Tax of the State of Connecticut; such taxes should not be included in the bid price. Upon request, exemption certificates will be furnished to the successful bidder.

13. FAIR EMPLOYMENT PRACTICES

The Contractor shall agree that neither it or its subcontractors, except in the case of a bona fide occupational qualification or need, to refuse to hire or employ or to bar or to discharge from employment any individual or to discriminate against such individual in compensation or in terms, conditions or privileges of employment because of the individual's race, color, religious creed, age, sex, gender identity or expression, marital status, national origin, ancestry, present or past history of mental disability, intellectual disability, learning disability, physical disability, including, but not limited to, blindness or status as a veteran. The aforementioned terms are obtained from Connecticut General Statutes Section 46a-60, *et seq.*, entitled "Discriminatory employment practices prohibited," as amended.

14. FORM OF AGREEMENT BETWEEN CITY OF MERIDEN AND CONTRACTOR

The Agreement for the work will be written on the Agreement between City of Meriden and Contractor, wherein the basis of payment is a stipulated sum.

15. LOCAL SUBCONTRACTORS, SUPPLIERS, etc.

Local subcontractors, material suppliers, and labor in the City of Meriden should be considered and sought out insofar as it is practical in the performance of this project.

16. CITY OF MERIDEN CODE OF ETHICS

The City of Meriden has adopted a Code of Ethics located in Chapter 21 of the Code of the City of Meriden, sections 21-1 through 21-15, inclusive, which are expressly incorporated herein by reference. The terms of the Code of Ethics shall constitute a part of any contract or agreement entered into by the City of Meriden as a result of this bid as if those terms were fully set forth in such contract or agreement.

Bidders are specifically advised that the Code of Ethics prohibits public officers and employees, as well as their immediate families and businesses, with which they are associated from participating in any transaction which is incompatible with the proper discharge of official duties or responsibilities. Bidders are also advised that the Code of Ethics contain provisions with respect to paid contractors and former employees and officials.

BIDDERS SHOULD NOTE THAT BIDS, CONTRACTS, AND AGREEMENTS ENTERED INTO OR AWARDED IN VIOLATION OF THE CODE OF ETHICS ARE VOIDABLE BY RESOLUTION OF THE CITY COUNCIL OF THE CITY OF MERIDEN.

Copies of the Code of Ethics may be obtained from the office of the City Clerk or may be found online on the City of Meriden's website.

17. NON-COLLUSION BID STATEMENT

Each bidder submitting a bid to the City of Meriden for any portion of the work contemplated by the documents on which bidding is based shall execute and attach thereto the sworn Non-Collusive Bid Statement, to the effect that the bidder has not colluded with any other person, firm, or corporation in the submission of the bid.

18. SOIL CONDITIONS

The City of Meriden does not guarantee the accuracy of any information which it may have obtained as to the kind or condition of the soil that may be encountered in the performance of the proposed work; neither does the City of Meriden represent that the plans and specifications drawn are based upon any soil data so obtained. The City of Meriden does not make any representations as to the soil data so obtained. The City of Meriden does not make any representations as to the soil conditions to be encountered or as to foundation materials.

19. AWARD IN CASE OF A TIE

In the event there are two or more responsive bidders, the decision to award will be based by the following criteria and in the following order:

- a. The incumbent will be awarded the bid over that of another bidder.
- b. In the case of a multi-item bid, if one bidder has been awarded other items from the same bid and the other bidder has not, the bidder with the multiple awards will be awarded the bid over that of another bidder.
- c. The bidder located in the State of Connecticut will be awarded the bid over that of another bidder.
- d. The winner of a coin toss will be awarded the bid over that of another bidder.

The above-referenced provisions do not apply to those situations in which more than one City-based business responsible bidder has submitted bids not more than ten (10) percent higher than the lowest bid and has agreed to accept the award of the bid at the amount of the lowest bid. Under such circumstances, the provisions of the Code of the City of Meriden, section 3-14, are controlling, as set forth under Section 8 of this 'Information to Bidders.'

20. ASSIGNMENT OF CONTRACT

No contract may be assigned without the written consent of the Purchasing Officer or designee.

21. PERMITS

The Contractor shall be responsible for obtaining any and all necessary permits required by the City of Meriden prior to the commencement of work. The Contractor may contact the

City of Meriden Building Department for permit information at (203) 630-4091. For all other required permits, contact the City of Meriden Engineering Department at (203) 630-4018.

22. BID PRICE AND PAYMENT

The City of Meriden is exempt from the payment of the excise taxes imposed by the Federal government and the Sales and Use Tax of the State of Connecticut under Connecticut General Statutes; accordingly, such taxes shall not be included in the bid price.

The City of Meriden, unless stated otherwise in the bidding documents or Contract, will make payment to the Contractor not less than thirty (30) days following completion of services.

23. QUALITY

All materials, equipment, supplies, and services shall be subject to rigid inspection. If defective material, equipment, supplies, or services are discovered, the Contractor shall remove or make good such material, equipment, or supplies without extra compensation. It is expressly understood and agreed that any inspection by the City of Meriden will in no way lessen the responsibility of the Contractor or release Contractor from the obligation to perform and deliver to the City sound and satisfactory materials, equipment, supplies, or allow the cost to be deducted from any monies due it from the City of Meriden. All services will be performed in a workmanlike manner.

24. INSURANCE

The successful bidder shall be required to provide a Certificate of Insurance denoting general liability, automobile liability, workers compensation liability, and other coverage required by the City's Risk Manager.

25. CITY HALL CLOSING

If Meriden City Hall is closed due to inclement weather, or any other unforeseen event, bids will be due at the same time on the next business day that City Hall is open.

26. PAYMENT REQUISITIONS & CERTIFIED PAYROLL

Progress payment requisitions are due monthly on last day of the month for work completed during the contract period. Requisitions are to be sent to the Architect/Engineer and/or City of Meriden Department responsible for management/administration of the contracted work.

Certified Payroll for construction contracts that require State of Connecticut Prevailing Wage Determinations are required for each week of work by the Contractor and any or all the Contractor's Subcontractors and are due monthly with each requisition. One hard copy and one electronic copy shall be sent to the Architect/Engineer and the City of Meriden

Purchasing Department. No progress payments will be issued to the Contractor without accompanying Certified Payroll.

For federally funded construction contracts with Davis Bacon Wage Determinations, Certified Payroll for all employees of the Contractor and any or all of the Contractor's Subcontractors are required to be submitted weekly to the Architect/Engineer and to the City of Meriden Purchasing Department. One hard copy and one electronic copy shall be sent to the Architect/Engineer and the City of Meriden Purchasing Department. Employees on the construction site will be interviewed by City of Meriden Staff and/or City of Meriden subcontracted Project Management/Clerk-of-the-Works/Owner's Representatives for Davis Bacon compliance. No progress payments will be issued to the Contractor without accompanying Certified Payroll.

27. CHRO - N/A

1. Minority owned business? _____ yes _____ no
2. Years organized. _____
3. Is your company a corporation _____ yes _____ no
If yes where incorporated? _____
4. How many years have you been engaged in business under your present firm name? _____
5. Former Firm Name (if any) _____
6. List total number of Personnel _____
7. Is any principal of your firm an employee or public official of the City of Meriden, or an immediate family member of an employee or public official of the City of Meriden? (Definition of immediate family includes: an individual's spouse, fiancé or fiancée; the parent, brother or sister of such individual or spouse; and the child of such individual or the spouse of such child.)
_____ yes _____ no
8. List Vehicles and Equipment that you will use to perform this work: (show age of vehicles and equipment, sizes, capacities, etc.)

9. List the work to be performed by Subcontractors and summarize the dollar value of each subcontract.

10. List the name and address of the more important contracts recently completed by you, starting the approximate gross cost for each, and the month and year completed:

11. General character of work performed by you _____

12. Have you ever failed to complete any contract awarded to you? If so, where and why?

13. Have you ever defaulted on a contract? If so where and why?

14. Have you ever filed bankruptcy: _____ Please explain: _____

15. Will you, upon request, furnish any information that may be required by the City of Meriden? _____
16. The undersigned hereby authorizes and request any person, firm or cooperation to furnish any information requested by the City of Meriden, in verification of the recitals comprising this Statement of Bidder's Qualifications.

Dated this _____ day of _____, 20____ year

 Name of Bidder

 Title

State of _____
 County of _____

_____ being duly sworn deposes and says that they are
 Name _____ of _____
 title _____ name of organization
 and that the answers to the forgoing question and all statement therein contained are true and correct

Subscribed and sworn to before me
 this _____ day of _____ 20____
 day month year

 Notary Public signature

My commission expires _____

FORM OF SURETY GUARANTY

(Shall accompany proposal)

KNOW ALL MEN BY THESE PRESENTS, that for and in consideration of the sum of \$1.00, lawful money of the United States, the receipt whereof is hereby acknowledged, paid the undersaid corporation, and for other valuable consideration the

(Name of Surety Company) .

a corporation organized and existing under the laws of the State of _____

and licensed to do business in the State of _____ certifies and agrees

that if Contract _____

is awarded to - _____
(Name of Bidder)

Corporation will execute the bond or bonds as required by the Contract Documents and will become surety in the full amount of the Contract price for the faithful performance of the Contract and for payment of all persons supplying labor or furnishing or furnishing materials in connection thencewith.

(Surety)

The language of this form shall generally be given on the official form normally provided by the Surety Company complete with the usual proof of Authority of Officers of the Surety Company to execute said official form.

Should a bid be offered with a check as surety without said official form, such bid shall be rejected.

BID BOND

KNOW ALL MEN BY THESE PRESENTS, that we, the undersigned

(Name of Principal)

As Principal, and _____, as Surety are firmly bound
(Name of Surety)

Unto the CITY OF MERIDEN, CONNECTICUT hereinafter called the "OWNER", in the penal sum of

_____ DOLLARS, (\$ _____) lawful money of the
United States, for the payment of which sum well and truly to be made, we bind ourselves, our heirs, executors,
administrators, successors and assigns, jointly and severally, firmly by these presents:

THE CONDITION OF THIS OBLIGATION IS SUCH THAT, WHEREAS, the said Principal has submitted the
Accompanying bid dated _____, 20 _____

For _____

NOW, THEREFORE, if the Principal shall not withdraw said Bid within the Period specified therein after the opening of the same, or if no period be specified, within thirty (30) days after the said opening and shall within the period specified therefore, or if no period be specified, within ten (10) days after the prescribed forms are presented to him for signature, enter into a written Contract with the Owner in accordance with the Bid, as accepted, and give bond with good and sufficient surety or sureties, as may be required for the faithful performance and proper fulfillment of such Contract; or in the event of the withdrawal of said Bid within the period specified, or the failure to enter into such Contract and give such bond within the time specified, if the Principal shall pay the Owner the difference between the amount specified in said Bid and the Amount for which the Owner may procure the required work or supplies or both, if the latter be in excess of the former, then the above obligation shall be void and of no effect, otherwise to remain in full force and effect.

IN WITNESS WHEREOF, the Principal and the Surety have hereunto set their hands and seals, this _____ day of _____, 20 .

(Principal)

(Address) (Affix seal)

Witness Signature

By: _____

(Surety)

(Address) (Affix seal)

Witness Signature

By: _____

BID FORM

B024-67

Sherman School HVAC System

Date of Opening: June 27, 2024
At 11:00 AM

To: Rawle Dummett
Purchasing Officer
142 East Main Street, Room 210
Meriden, CT 06450

The undersigned _____, doing business in the City/Town of _____, in the State of _____, herewith, after reading thoroughly the Specifications and other Bid documents (including if any addendum or addenda) submit the following proposal:

Lump sum price:

_____ Dollars & Cents
Written Amount

Receipt of Addenda is acknowledged:

No: _____ Dated: _____

No: _____ Dated: _____

NAME OF BIDDER _____

ADDRESS _____

BY: _____
Print or type name Title

SIGNATURE _____ DATE _____

TELEPHONE _____ E-Mail _____

-

PLEASE NOTE: All spaces must be filled in with figures or words or your bid may be automatically rejected. Attach your Certified Check or Bid Bond, the Non-Collusive Bid Statement and the Bidder's Qualifications

STANDARD FORM OF AGREEMENT
BETWEEN OWNER AND CONTRACTOR
ON THE BASIS OF A STIPULATED PRICE
B024-67 Sherman Elementary School HVAC Upgrade

THIS AGREEMENT is dated as of the _____ day of _____ by and between the City of Meriden, 142 East Main Street Meriden, CT 06450 hereinafter called OWNER and _____ hereinafter called CONTRACTOR.

OWNER and CONTRACTOR, in consideration of the mutual covenants hereinafter set forth, agree as follows:

Article 1. WORK.

CONTRACTOR shall complete all Work as specified or indicated in the Contract Documents. The Work is generally described as follows: Furnish labor and materials to replace the A/C at Roger Sherman Elementary School.

The Project for which the Work under the Contract Documents may be the whole or only a part is generally described as follows: Furnish labor and materials to replace the boiler at:

Article 2. ENGINEER.

The Project has been designed by Bemis Associates, LLC, 185 Main Street, Farmington, CT 06032 who is hereinafter called ENGINEER and who is to act as Owner's representative, assume all duties and responsibilities and has the rights and authority assigned to ENGINEER in the Contract Documents in connection with completion of the Work in accordance with the contract documents.

Article 3. CONTRACT TIMES.

3.1 The Work will be substantially completed by _____ after the date the Contract Times commence to run as provided in paragraph 2.03 of the General Conditions, and completed and ready for final payment in accordance with paragraph 14.07B of the General Conditions by _____ after the date when the Contract Times commence to run.

3.2 Liquidated Damages. OWNER and CONTRACTOR recognize that time is of the essence of this Agreement and that OWNER will suffer financial loss if the Work is not completed within the times specified in paragraph 3.1 above, plus any extensions thereof allowed in accordance with Article 12 of the General Conditions. They also recognize the delays, expense and difficulties involved in proving the actual loss suffered by OWNER if the Work is not completed on time. Accordingly, instead of requiring any such proof, OWNER and CONTRACTOR agree that as liquidated damages for delay (but not as a penalty) CONTRACTOR shall pay OWNER Two Hundred Fifty Dollars (**\$250.00**) for each day that expires after the time specified in paragraph 3.1 for Substantial Completion until the Work is substantially complete. After Substantial Completion, if CONTRACTOR shall neglect, refuse or fail to complete the remaining Work within the time specified in paragraph 3.1 for completion and readiness for final payment or any proper extension thereof granted by OWNER, CONTRACTOR shall pay OWNER Two Hundred Fifty Dollars (**\$250.00**) for each day that expires after the time specified in paragraph 3.1 for completion and readiness for final payment.

OWNER Two Hundred Fifty Dollars (**\$250.00**) for each day that expires after the time specified in paragraph 3.1 for Substantial Completion until the Work is substantially complete. After Substantial Completion, if CONTRACTOR shall neglect, refuse or fail to complete the remaining Work within the time specified in paragraph 3.1 for completion and readiness for final payment or any proper extension thereof granted by OWNER, CONTRACTOR shall pay OWNER Two Hundred Fifty Dollars (**\$250.00**) for each day that expires after the time specified in paragraph 3.1 for completion and readiness for final payment.

Article 4. CONTRACT PRICE.

OWNER shall pay CONTRACTOR for completion of the Work in accordance with the Contract Documents an amount in current funds equal to the sum of the amounts determined pursuant to paragraphs 4.1 and 4.2 below:

4.1. For all Work, other than Unit Price Work, a Lump Sum of:

Figures:

Written: _____

All specific cash allowances are included in the above price and have been computed in accordance with 11.02 of the General Conditions;

Plus
4.2. For all Unit Price Work, an amount equal to the sum of the established unit price for each separately identified item of Unit Price Work times the estimated quantity of that item as indicated in this paragraph 4.2:

UNIT PRICE WORK

NO.	ITEM	UNIT	ESTIMATED QUANTITY	UNIT PRICE	TOTAL ESTIMATED
TOTAL OF ALL UNIT PRICES:				\$	
_____				_____	
Written				Figures	

As provided in paragraph 11.03 of the General Conditions estimated quantities are not guaranteed, and determinations of actual quantities and classification are to be made by ENGINEER as provided in paragraph 9.07 of the General Conditions. Unit prices have been computed as provided in paragraph 11.03C of the General Conditions.

(The Bid may be attached. Any attachments and/or exhibits attached should be listed in Article 8).

If adjustment prices for variations from stipulated Base Bid quantities have been agreed to, insert appropriate provisions.

Article 5. PROGRESS PAYMENTS.

- 5.1 Based upon applications for Payment submitted to the Engineer by the Contractor and Certificates for Payment issued by the Engineer, the Owner shall make progress payments on account to the Contractor as provided below and elsewhere in the Contract Documents.
- 5.2 The period covered by each Application for Payment shall be one calendar month ending on the last day of the month.
- 5.3 Each Application for Payment shall be based upon the Schedule of Values submitted by the Contractor in accordance with the Contract Documents. The Schedule of Values shall allocate the entire Contract Sum among the various portions of the Work and be prepared in such form and supported by such data to substantiate its accuracy as the Engineer may require. This Schedule, unless objected to by the Engineer, shall be used as a basis for reviewing the Contractor's Applications for Payment.
- 5.4 Applications for Payment shall indicate the percentage of completion of each portion of the Work as of the end of the period covered by the Application for Payment.
- 5.5 Subject to the provisions of the Contract Documents, the amount of each progress payment shall be computed as follows:

5.6.1 Take that portion of the Contract sum properly allocable to completed work as determined by multiplying the percentage completion of each portion of the Work by the share of the total Contract Sum allocated to that portion of the work in the Schedule of Values, less retainage of five percent (5 percent). Pending final determination of cost to the Owner of changes in the Work, amounts not in dispute may be included as provided in appropriate sections of the General Conditions even though the Contract Sum has not yet been adjusted by Change Order.

5.6.2 Add that portion of the Contract Sum properly allocable to materials and equipment delivered and suitably stored at the site for subsequent incorporation in the completed construction (or, if approved in advance by the Owner, suitably stored off the site at a location agreed upon in writing) less retainage of five percent (5 percent).

5.6.3 Subtract the aggregate of previous payments made by the Owner; and

5.6.4 Subtract amounts, if any, for which the Engineer has withheld or nullified a Certificate for Payment as provided in Paragraph 14.02.B.5 of the General Conditions.

5.7 The progress payment amount determined in accordance with Paragraph 5.6 shall be further modified under the following circumstances;

(Not applicable)

5.7.1 Add, upon Substantial Completion of the Work, a sum sufficient to increase the total payments to ninety-five percent (95) of the Contract Sum, less such amounts as the Engineer shall determine for incomplete Work and unsettled claims; and

Standard Form of Agreement: Page 4

5.7.2 Add, if final completion of the Work is thereafter materially delayed, through no fault of the Contractor, additional amounts payable in accordance with Paragraph 14.08 of the General Conditions.

5.8 Reduction or limitation of retainage, if any shall be as follows:

(Not applicable)

5.9 Progress payment requisitions are due monthly on last day of the month for work completed during the contract period. Requisitions are to be sent to the Architect/Engineer and/or City of Meriden Department responsible for management/administration of the contracted work.

Certified Payroll for construction contracts that require State of Connecticut Prevailing Wage Determinations are required for each week of work by the Contractor and any or all the Contractor's Subcontractors and are due monthly with each requisition. One hard copy and one electronic copy shall be sent to the Architect/Engineer and the City of Meriden Purchasing Department. No progress payments will be issued to the Contractor without accompanying Certified Payroll.

For federally funded construction contracts with Davis Bacon Wage Determinations, Certified Payroll for all employees of the Contractor and any or all of the Contractor's Subcontractors are required to be submitted weekly to the Architect/Engineer and to the City of Meriden Purchasing Department. One hard copy and one electronic copy shall be sent to the Architect/Engineer and the City of Meriden Purchasing Department. Employees on the construction site will be interviewed by City of Meriden Staff and/or City of Meriden subcontracted Project Management/Clerk-of-the-Works/Owner's Representatives for Davis Bacon compliance. No progress payments will be issued to the Contractor without accompanying Certified Payroll.

Article 6. INTEREST.

No interest shall be due or paid on any monies not paid when due.

Article 7. CONTRACTOR'S REPRESENTATIONS.

In order to induce OWNER to enter into this Agreement CONTRACTOR makes the following representations:

7.1. CONTRACTOR has examined and carefully studied the Contract Documents including the Addenda listed in paragraph 8 and the other related data identified in the Bidding Documents including "technical data."

7.2. CONTRACTOR has visited the site and become familiar with and is satisfied as to the general, local and site conditions that may affect cost, progress, performance or furnishing of the Work.

7.3. CONTRACTOR is familiar with and is satisfied as to all federal, state and local Laws and Regulations that may affect cost, progress, performance and furnishing of the Work.

7.4. CONTRACTOR has carefully studied all reports of explorations and tests of subsurface conditions at or contiguous to the site and all drawings of physical conditions in or relating to existing surface or subsurface structures at or contiguous to the site (except Underground Facilities) which have been identified in the Supplementary Conditions as provided in paragraph 4.02 of the General Conditions. CONTRACTOR accepts the determination of the extent of the "technical data" contained in such reports and drawings upon which CONTRACTOR is entitled to rely. CONTRACTOR acknowledges that such reports and drawings are not
Standard Form of Agreement: Page 5

Contract Documents and may not be complete for Contractor's purposes. CONTRACTOR acknowledges that OWNER and ENGINEER do not assume responsibility for the accuracy or completeness of information and Data shown or indicated in the Contract Documents with respect to Underground Facilities at or contiguous to the site. CONTRACTOR has obtained and carefully studied assumes responsibility for having done so) all such additional supplementary examinations, investigations, explorations, tests, studies and data concerning conditions (surface, subsurface and Underground Facilities) at or contiguous to the site or otherwise which may

affect cost, progress, performance or furnishing of the Work or which relate to any aspect of the means, methods, techniques, sequences and procedures of construction to be employed by CONTRACTOR and safety precautions and programs incident thereto. CONTRACTOR does not consider that any additional examinations, investigations, explorations, tests, studies or data are necessary for the performance and furnishing of the Work at the Contract Price, within the Contract Times and in accordance with the other terms and conditions of the contract Documents.

7.5. CONTRACTOR is aware of the general nature of work to be performed by OWNER and others at the site that relates to the Work as indicated in the Contract Documents.

7.6. CONTRACTOR has correlated the information known to CONTRACTOR, information and observation obtained from visits to the site, reports and drawings identified in the Contract Documents and all additional examinations, investigations, explorations, tests, studies and data with the Contract Documents.

7.7. CONTRACTOR has given ENGINEER written notice of all conflicts, errors, ambiguities or discrepancies that CONTRACTOR has discovered in the Contract Documents and the written resolution thereof by ENGINEER is acceptable to CONTRACTOR, and the Contract Documents are generally sufficient to indicate and convey understanding of all terms and conditions for performance and furnishing of the Work.

Article 8. CONTRACT DOCUMENTS.

The Contract Documents, which comprise the entire agreement between OWNER and CONTRACTOR concerning the Work, consist of the following:

8.1. This Agreement.

8.2. General Conditions and Supplemental General Conditions.

8.3. Notice of Award – **Attachment A**

8.4. Performance, Payment, and other Bonds – **Attachment B.**

8.5. Insurance certificate – **Attachment C**

8.6. Contractor's Bid Proposal, Non-Collusive Bid Statement, Bidder's Qualification Statement, St of CT Forms that are applicable - **Attachment D**

8.7. Connecticut Department of Labor – Wage and Workplace Standards Division.

8.8. **“By Reference”**: The complete Specifications as included in the bidding documents bearing the title.

8.9. **“By Reference”**: List of Drawings: Sheet No's. ___ through ___ included in the bidding documents. The above documents are on file in the City of Meriden's Purchasing Department.

Standard Form of Agreement: Page 6

8.10. Addenda numbers _____.

(Those addenda which pertain exclusively to the bidding process need not be listed.)

8.11. The following which may be delivered or issued after the Effective Date of the Agreement and are not attached hereto: All-Written Amendments and other documents amending, modifying or supplementing the Contract Documents pursuant to paragraphs 3.04 and 3.05 of the General Conditions.

There are no Contract Documents other than those listed above. The Contract Documents may only be amended, modified or supplemented as provided in paragraphs 3.04 and 3.05 of the General Conditions.

Article 9. MISCELLANEOUS.

9.1. Terms used in this Agreement which are defined in Article I of the General Conditions will have the meanings indicated in the General Conditions.

9.2. No assignment by a party hereto of any rights under or interests in the Contract Documents will be binding on another party hereto without the written consent of the party sought to be bound; and, specifically but without limitation, moneys that may become due and moneys that are due may not be assigned without such consent (except to the extent that the effect of this restriction may be limited by law), and unless specifically stated to the contrary in any written consent to an assignment no assignment will release or discharge the assignor from any duty or responsibility under the Contract Documents.

9.3. OWNER and CONTRACTOR each binds itself, its partners, successors, assigns and legal representatives to the other party hereto, its partners, successors, assigns and legal representatives in respect to all covenants, agreements and obligations contained in the Contract Documents.

9.4. Any provision or part of the Contract Documents held to be void or unenforceable under any Law or Regulation shall be deemed stricken, and all remaining provisions shall continue to be valid and binding upon OWNER and CONTRACTOR, who agree that the Contract Documents shall be reformed to replace such stricken provision or part thereof with a valid and enforceable provision that comes as close as possible to expressing the intention of the stricken provision.

9.5 OTHER PROVISIONS.

WITNESS WHEREOF, the parties hereto have affixed their names and seals.

THE CITY OF MERIDEN

CONTRACTOR:

Emily E Holland, Acting City Manager
Duly Authorized

Duly Authorized

Date: _____

Date: _____



Opportunity * Guidance * Support



THIS IS A PUBLIC WORKS PROJECT

Covered by the

PREVAILING WAGE LAW

CT General Statutes Section 31-53

**If you have QUESTIONS regarding your wages
CALL (860) 263-6790**

Section 31-55 of the CT State Statutes requires every contractor or subcontractor performing work for the state to post in a prominent place the prevailing wages as determined by the Labor Commissioner.

Minimum Rates and Classifications
for Building Construction

ID#: 24-62000

Connecticut Department of Labor
Wage and Workplace Standards Division

By virtue of the authority vested in the Labor Commissioner under provisions of Section 31-53 of the General Statutes of Connecticut, as amended, the following are declared to be the prevailing rates and welfare payments and will apply only where the contract is advertised for bid within 20 days of the date on which the rates are established. Any contractor or subcontractor not obligated by agreement to pay to the welfare and pension fund shall pay this amount to each employee as part of his/her hourly wages.

Project Number: B024-67

Project Town: Meriden

State#:

FAP#:

Project: Roger Sherman Elementary School: HVAC System Replacement

CLASSIFICATION	Hourly Rate	Benefits
1b) Asbestos/Toxic Waste Removal Laborers: Asbestos removal and encapsulation (except its removal from mechanical systems which are not to be scrapped), toxic waste removers, blasters. **See Laborers Group 7**		
1c) Asbestos Worker/Heat and Frost Insulator	45.56	32.65
2) Boilermaker	46.21	29.35
3a) Bricklayer, Cement Mason, Concrete Finisher (including caulking), Stone Masons	41.11	34.65 + a
3b) Tile Setter	37.1	30.52
3c) Tile and Stone Finishers	30.0	25.30
3d) Marble & Terrazzo Finishers	31.07	24.23
3e) Plasterer	42.77	29.63

-----LABORERS-----

4) Group 1: General laborers, carpenter tenders, concrete specialists, wrecking laborers and fire watchers.	34.5	27.26
4) Group 1a: Acetylene Burners (Hours worked with a torch)	35.5	27.26
4a) Group 2: Mortar mixers, plaster tender, power buggy operators, powdermen, fireproofers/mixer/nozzleman (Person running mixer and spraying fireproof only).	34.75	27.26
4b) Group 3: Jackhammer operators/pavement breaker, mason tender (brick), mason tender (cement/concrete), forklift operators and forklift operators (masonry).	35.0	27.26
4c) **Group 4: Pipelayers (Installation of water, storm drainage or sewage lines outside of the building line with P6, P7 license) (the pipelayer rate shall apply only to one or two employees of the total crew who primary task is to actually perform the mating of pipe sections) P6 and P7 rate is \$26.80.	35.5	27.26
4d) Group 5: Air track operator, sand blaster and hydraulic drills.	35.25	27.26
4e) Group 6: Blasters, nuclear and toxic waste removal.	37.5	27.26
4f) Group 7: Asbestos/lead removal and encapsulation (except it's removal from mechanical systems which are not to be scrapped).	37.5	27.26
4g) Group 8: Bottom men on open air caisson, cylindrical work and boring crew.	35.0	27.26
4h) Group 9: Top men on open air caisson, cylindrical work and boring crew.	34.5	27.26
4i) Group 10: Traffic Control Signalman	20.7	27.26
4j) Group 11: Toxic Waste Removers A or B With PPE	37.5	27.26

As of: May 23, 2024

5) Carpenter, Acoustical Ceiling Installation, Soft Floor/Carpet Laying, Metal Stud Installation, Form Work and Scaffold Building, Drywall Hanging, Modular-Furniture Systems Installers, Lathers, Piledrivers, Resilient Floor Layers.	39.54	28.68
5a) Millwrights	40.56	28.87
6) Electrical Worker (including low voltage wiring) (Trade License required: E1,2 L-5,6 C-5,6 T-1,2 L-1,2 V-1,2,7,8,9)	42.6	33.21+3% of gross wage
7a) Elevator Mechanic (Trade License required: R-1,2,5,6)	64.01	39.19+a+b
-----LINE CONSTRUCTION-----		
Groundman	26.5	6.5% + 9.00
Linemen/Cable Splicer	48.19	6.5% + 22.00
8) Glazier (Trade License required: FG-1,2)	41.18	24.55 + a
9) Ironworker, Ornamental, Reinforcing, Structural, and Precast Concrete Erection	42.37	40.02 + a
----OPERATORS----		
Group 1: Crane Handling or Erecting Structural Steel or Stone; Hoisting Engineer (2 drums or over). (Trade License Required)	55.42	28.80 + a
Group 1a: Front End Loader (7 cubic yards or over); Work Boat 26 ft. and Over	50.79	28.80 + a
Group 2: Cranes (100 ton rate capacity and over); Bauer Drill/Caisson. (Trade License Required)	55.03	28.80 + a

As of: May 23, 2024

Group 2a: Cranes (under 100 ton rated capacity).	54.09	28.80 + a
Group 2b: Excavator over 2 cubic yards; Pile Driver (\$3.00 premium when operator controls hammer)	50.4	28.80 + a
Group 3: Excavator; Gradall; Master Mechanic; Hoisting Engineer (all types of equipment where a drum and cable are used to hoist or drag material regardless of motive power of operation), Rubber Tire Excavator (Drott-1085 or similar); Grader Operator; Bulldozer Finegrade. (slopes, shaping, laser or GPS, etc.). (Trade License Required)	49.45	28.80 + a
Group 4: Trenching Machines; Lighter Derrick; CMI Machine or Similar; Koehring Loader (Skooper); Goldhofer.	48.97	28.80 + a
Group 5: Specialty Railroad Equipment; Asphalt Spreader, Asphalt Reclaiming Machine; Line Grinder; Concrete Pumps; Drills with Self Contained Power Units; Boring Machine; Post Hole Digger; Auger; Pounder; Well Digger; Milling Machine (over 24 mandrel).	48.22	28.80 + a
Group 5 continued: Side Boom; Combination Hoe and Loader; Directional Driller.	48.22	28.80 + a
Group 6: Front End Loader (3 up to 7 cubic yards); Bulldozer (rough grade dozer).	47.83	28.80 + a
Group 7: Asphalt Roller; Concrete Saws and Cutters (ride on types); Vermeer Concrete Cutter; Stump Grinder; Scraper; Snooper; Skidder; Milling Machine (24" and under mandrel).	47.4	28.80 + a
Group 8: Mechanic; Grease Truck Operator; Hydroblaster; Barrier Mover; Power Stone Spreader; Welding; Work Boat Under 26 ft.; Transfer Machine; Rigger Foreman.	46.9	28.80 + a
Group 9: Front End Loader (under 3 cubic yards); Skid Steer Loader regardless of attachments; (Bobcat or Similar); Forklift, Power Chipper; Landscape Equipment (including Hydroseeder); Vacuum Excavation Truck and Hydrovac Excavation Truck (27 HG pressure or greater).	46.35	28.80 + a

Group 10: Vibratory hammer; ice machine; diesel and air, hammer, etc.	43.77	28.80 + a
Group 11: Conveyor, earth roller, power pavement breaker (whiphammer), robot demolition equipment.	43.77	28.80 + a
Group 12: Wellpoint Operator.	43.69	28.80 + a
Group 13: Compressor Battery Operator.	42.97	28.80 + a
Group 14: Elevator Operator; Tow Motor Operator (solid tire no rough terrain).	41.52	28.80 + a
Group 15: Generator Operator; Compressor Operator; Pump Operator; Welding Machine Operator; Heater Operator.	41.01	28.80 + a
Group 16: Maintenance Engineer.	40.19	28.80 + a
Group 17: Portable Asphalt Plant Operator; Portable Crusher Plant Operator; Portable Concrete Plant Operator; Portable Grout Plant Operator; Portable Water Filtration Plant Operator.	45.63	28.80 + a
Group 18: Power Safety Boat; Vacuum Truck; Zim Mixer; Sweeper; (Minimum for any job requiring a CDL license); Rigger; Signalman.	42.57	28.80 + a
Surveyor: Chief of Party	45.87	28.80 + a
Surveyor: Assistant Chief of Party	42.3	28.80 + a
Surveyor: Instrument Man	40.7	28.80 + a
Surveyor: Rodman or Chainman	35.03	28.80 + a

-----PAINTERS (Including Drywall Finishing)-----

As of: May 23, 2024

10a) Brush and Roller	37.62	24.55
10b) Taping Only/Drywall Finishing	38.37	24.55
10c) Paperhanger and Red Label	38.12	24.55
10e) Blast and Spray	40.62	24.55
11) Plumber (excluding HVAC pipe installation) (Trade License required: P-1,2,6,7,8,9 J-1,2,3,4 SP-1,2)	48.28	35.50
12) Well Digger, Pile Testing Machine	37.26	24.05 + a
13) Roofer (composition)	41.8	21.40
14) Roofer (slate & tile)	42.3	21.40
15) Sheetmetal Worker (Trade License required for HVAC and Ductwork: SM-1,SM-2,SM-3,SM-4,SM-5,SM-6)	41.89	43.22
16) Pipefitter (Including HVAC work) (Trade License required: S-1,2,3,4,5,6,7,8 B-1,2,3,4 D-1,2,3,4, G-1, G-2, G-8 & G-9)	48.28	35.50
-----TRUCK DRIVERS-----		
17a) 2 Axle, Helpers	33.16	32.36 + a
17b) 3 Axle, 2 Axle Ready Mix	33.27	32.36 + a

17c) 3 Axle Ready Mix	33.33	32.36 + a
17d) 4 Axle	33.39	32.36 + a
17e) 4 Axle Ready Mix	33.44	32.36 + a
17f) Heavy Duty Trailer (40 Tons and Over)	35.66	32.36 + a
17g) Specialized Earth Moving Equipment (Other Than Conventional Type on-the-Road Trucks and Semi-Trailers, Including Euclids)	33.44	32.36 + a
17h) Heavy Duty Trailer up to 40 tons	34.39	32.36 + a
17i) Snorkle Truck	33.54	32.36 + a
18) Sprinkler Fitter (Trade License required: F-1,2,3,4)	49.98	32.85 + a
19) Theatrical Stage Journeyman	25.76	7.34

Welders: Rate for craft to which welding is incidental.

Surveyors: Hazardous material removal: \$3.00 per hour premium.

*Note: Hazardous waste removal work receives additional \$1.25 per hour for truck drivers.

**Note: Hazardous waste premium \$3.00 per hour over classified rate

Crane with 150 ft. boom (including jib) - \$1.50 extra

Crane with 200 ft. boom (including jib) - \$2.50 extra

Crane with 250 ft. boom (including jib) - \$5.00 extra

Crane with 300 ft. boom (including jib) - \$7.00 extra

Crane with 400 ft. boom (including jib) - \$10.00 extra

All classifications that indicate a percentage of the fringe benefits must be calculated at the percentage rate times the "base hourly rate".

Apprentices duly registered under the Commissioner of Labor's regulations on "Work Training Standards for Apprenticeship and Training Programs" Section 31-51-d-1 to 12, are allowed to be paid the appropriate percentage of the prevailing journeymen hourly base and the full fringe benefit rate, providing the work site ratio shall not be less than one full-time journeyman instructing and supervising the work of each apprentice in a specific trade.

The Prevailing wage rates applicable to this project are subject to annual adjustments each July 1st for the duration of the project.

Each contractor shall pay the annual adjusted prevailing wage rate that is in effect each July 1st, as posted by the Department of Labor.

It is the contractor's responsibility to obtain the annual adjusted prevailing wage rate increases directly from the Department of Labor's website.

The annual adjustments will be posted on the Department of Labor's Web page:

www.ct.gov/dol. For those without internet access, please contact the division listed below.

The Department of Labor will continue to issue the initial prevailing wage rate schedule to the Contracting Agency for the project.

All subsequent annual adjustments will be posted on our Web Site for contractor access.

Contracting Agencies are under no obligation pursuant to State labor law to pay any increase due to the annual adjustment provision.

Effective October 1, 2005 - Public Act 05-50: any person performing the work of any mechanic, laborer, or worker shall be paid prevailing wage

All Person who perform work ON SITE must be paid prevailing wage for the appropriate mechanic, laborer, or worker classification.

All certified payrolls must list the hours worked and wages paid to All Persons who perform work ON SITE regardless of their ownership i.e.: (Owners, Corporate Officers, LLC Members, Independent Contractors, et. al)

Reporting and payment of wages is required regardless of any contractual relationship alleged to exist between the contractor and such person.

~~Unlisted classifications needed for work not included within the scope of the classifications listed may be added after award only as provided in the labor standards contract clause (29 CFR 5.5 (a) (1) (ii)).

Please direct any questions which you may have pertaining to classification of work and payment of prevailing wages to the Wage and Workplace Standards Division, telephone (860)263-6790.

As of: May 23, 2024

As of: May 23, 2024

Sec. 31-53b. Construction safety and health course. New miner training program. Proof of completion required for mechanics, laborers and workers on public works projects. Enforcement. Regulations. Exceptions. (a) Each contract for a public works project entered into on or after July 1, 2009, by the state or any of its agents, or by any political subdivision of the state or any of its agents, described in subsection (g) of section 31-53, shall contain a provision requiring that each contractor furnish proof with the weekly certified payroll form for the first week each employee begins work on such project that any person performing the work of a mechanic, laborer or worker pursuant to the classifications of labor under section 31-53 on such public works project, pursuant to such contract, has completed a course of at least ten hours in duration in construction safety and health approved by the federal Occupational Safety and Health Administration or, has completed a new miner training program approved by the Federal Mine Safety and Health Administration in accordance with 30 CFR 48 or, in the case of telecommunications employees, has completed at least ten hours of training in accordance with 29 CFR 1910.268.

(b) Any person required to complete a course or program under subsection (a) of this section who has not completed the course or program shall be subject to removal from the worksite if the person does not provide documentation of having completed such course or program by the fifteenth day after the date the person is found to be in noncompliance. The Labor Commissioner or said commissioner's designee shall enforce this section.

(c) Not later than January 1, 2009, the Labor Commissioner shall adopt regulations, in accordance with the provisions of chapter 54, to implement the provisions of subsections (a) and (b) of this section. Such regulations shall require that the ten-hour construction safety and health courses required under subsection (a) of this section be conducted in accordance with federal Occupational Safety and Health Administration Training Institute standards, or in accordance with Federal Mine Safety and Health Administration Standards or in accordance with 29 CFR 1910.268, as appropriate. The Labor Commissioner shall accept as sufficient proof of compliance with the provisions of subsection (a) or (b) of this section a student course completion card issued by the federal Occupational Safety and Health Administration Training Institute, or such other proof of compliance said commissioner deems appropriate, dated no earlier than five years before the commencement date of such public works project.

(d) This section shall not apply to employees of public service companies, as defined in section 16-1, or drivers of commercial motor vehicles driving the vehicle on the public works project and delivering or picking up cargo from public works projects provided they perform no labor relating to the project other than the loading and unloading of their cargo.

(P.A. 06-175, S. 1; P.A. 08-83, S. 1.)

History: P.A. 08-83 amended Subsec. (a) by making provisions applicable to public works project contracts entered into on or after July 1, 2009, replacing provision re total cost of work with reference to Sec. 31-53(g), requiring proof in certified payroll form that new mechanic, laborer or worker has completed a 10-hour or more construction safety course and adding provision re new miner training program, amended Subsec. (b) by substituting "person" for "employee" and adding "or program", amended Subsec. (c) by adding "or in accordance with Federal Mine Safety and Health Administration Standards" and setting new deadline of January 1, 2009, deleted former Subsec. (d) re "public building", added new Subsec. (d) re exemptions for public service company employees and delivery drivers who perform no labor other than delivery and made conforming and technical changes, effective January 1, 2009.

STATUTE 31-55a

- SPECIAL NOTICE -

To: All State and Political Subdivisions, Their Agents, and Contractors

Connecticut General Statute 31-55a - Annual adjustments to wage rates by contractors doing state work.

Each contractor that is awarded a contract on or after October 1, 2002, for (1) the construction of a state highway or bridge that falls under the provisions of section 31-54 of the general statutes, or (2) the construction, remodeling, refinishing, refurbishing, rehabilitation, alteration or repair of any public works project that falls under the provisions of section 31-53 of the general statutes shall contact the Labor Commissioner on or before July first of each year, for the duration of such contract, to ascertain the prevailing rate of wages on an hourly basis and the amount of payment or contributions paid or payable on behalf of each mechanic, laborer or worker employed upon the work contracted to be done, and shall make any necessary adjustments to such prevailing rate of wages and such payment or contributions paid or payable on behalf of each such employee, effective each July first.

- The prevailing wage rates applicable to any contract or subcontract awarded on or after October 1, 2002 are subject to annual adjustments each July 1st for the duration of any project which was originally advertised for bids on or after October 1, 2002.
- Each contractor affected by the above requirement shall pay the annual adjusted prevailing wage rate that is in effect each July 1st, as posted by the Department of Labor.
- It is the **contractor's** responsibility to obtain the annual adjusted prevailing wage rate increases directly from the Department of Labor's Web Site. The annual adjustments will be posted on the Department of Labor Web page: www.ctdol.state.ct.us. For those without internet access, please contact the division listed below.
- The Department of Labor will continue to issue the initial prevailing wage rate schedule to the Contracting Agency for the project. All subsequent annual adjustments will be posted on our Web Site for contractor access.

Any questions should be directed to the Contract Compliance Unit, Wage and Workplace Standards Division, Connecticut Department of Labor, 200 Folly Brook Blvd., Wethersfield, CT 06109 at (860)263-6790.

~NOTICE~

TO ALL CONTRACTING AGENCIES

Please be advised that Connecticut General Statutes Section 31-53, requires the contracting agency to certify to the Department of Labor, the total dollar amount of work to be done in connection with such public works project, regardless of whether such project consists of one or more contracts.

Please find the attached “Contracting Agency Certification Form” to be completed and returned to the Department of Labor, Wage and Workplace Standards Division, Public Contract Compliance Unit.

 Inquiries can be directed to (860)263-6543.

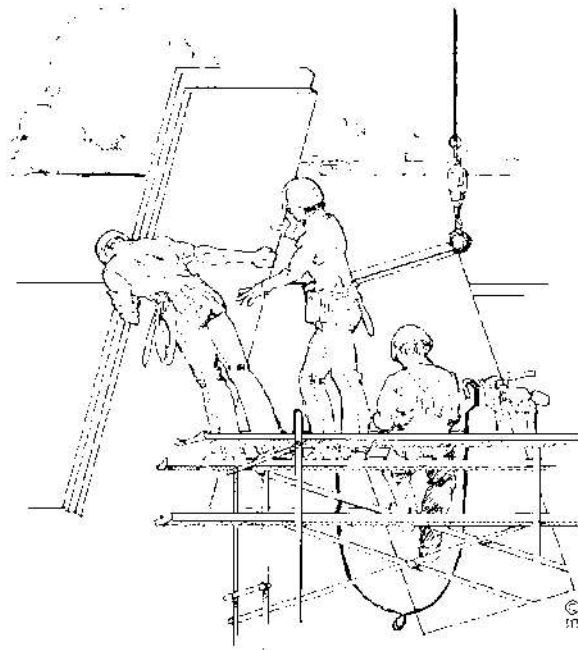

CONNECTICUT DEPARTMENT OF LABOR
WAGE AND WORKPLACE STANDARDS DIVISION
CONTRACT COMPLIANCE UNIT

CONTRACTING AGENCY CERTIFICATION FORM

I, _____, acting in my official capacity as _____,
authorized representative title

for _____, located at _____,
contracting agency address

do hereby certify that the total dollar amount of work to be done in connection with
_____, located at _____,
project name and number address

shall be \$_____, which includes all work, regardless of whether such project
consists of one or more contracts.

CONTRACTOR INFORMATION

Name: _____

Address: _____

Authorized Representative: _____

Approximate Starting Date: _____

Approximate Completion Date: _____

Signature

Date

Return To: Connecticut Department of Labor
Wage & Workplace Standards Division
Contract Compliance Unit
200 Folly Brook Blvd.
Wethersfield, CT 06109

Date Issued: _____

CONNECTICUT DEPARTMENT OF LABOR
WAGE AND WORKPLACE STANDARDS DIVISION

CONTRACTORS WAGE CERTIFICATION FORM
Construction Manager at Risk/General Contractor/Prime Contractor

I, _____ of _____
Officer, Owner, Authorized Rep. Company Name

do hereby certify that the _____
Company Name

Street

City

and all of its subcontractors will pay all workers on the

Project Name and Number

Street and City

the wages as listed in the schedule of prevailing rates required for such project (a copy of which is attached hereto).

Signed

Subscribed and sworn to before me this _____ day of _____, _____.

Notary Public

Return to:
Connecticut Department of Labor
Wage & Workplace Standards Division
200 Folly Brook Blvd.
Wethersfield, CT 06109

Rate Schedule Issued (Date): _____

Informational Bulletin

THE 10-HOUR OSHA CONSTRUCTION SAFETY AND HEALTH COURSE

(applicable to public building contracts entered into *on or after July 1, 2007*, where the total cost of all work to be performed is at least \$100,000)

- (1) This requirement was created by Public Act No. 06-175, which is codified in Section 31-53b of the Connecticut General Statutes (pertaining to the prevailing wage statutes);
- (2) The course is required for public building construction contracts (projects funded in whole or in part by the state or any political subdivision of the state) entered into on or after July 1, 2007;
- (3) It is required of private employees (not state or municipal employees) and apprentices who perform manual labor for a general contractor or subcontractor on a public building project where the total cost of all work to be performed is at least \$100,000;
- (4) The ten-hour construction course pertains to the ten-hour Outreach Course conducted in accordance with federal OSHA Training Institute standards, and, for telecommunications workers, a ten-hour training course conducted in accordance with federal OSHA standard, 29 CFR 1910.268;
- (5) The internet website for the federal OSHA Training Institute is http://www.osha.gov/fso/ote/training/edcenters/fact_sheet.html;
- (6) The statutory language leaves it to the contractor and its employees to determine who pays for the cost of the ten-hour Outreach Course;
- (7) Within 30 days of receiving a contract award, a general contractor must furnish proof to the Labor Commissioner that all employees and apprentices performing manual labor on the project will have completed such a course;
- (8) Proof of completion may be demonstrated through either: (a) the presentation of a *bona fide* student course completion card issued by the federal OSHA Training Institute; *or* (2) the presentation of documentation provided to an employee by a trainer certified by the Institute pending the actual issuance of the completion card;
- (9) Any card with an issuance date more than 5 years prior to the commencement date of the construction project shall not constitute proof of compliance;

- (10) Each employer shall affix a copy of the construction safety course completion card to the certified payroll submitted to the contracting agency in accordance with Conn. Gen. Stat. § 31-53(f) on which such employee's name first appears;
- (11) Any employee found to be in non-compliance shall be subject to removal from the worksite if such employee does not provide satisfactory proof of course completion to the Labor Commissioner by the fifteenth day after the date the employee is determined to be in noncompliance;
- (12) Any such employee who is determined to be in noncompliance may continue to work on a public building construction project for a maximum of fourteen consecutive calendar days while bringing his or her status into compliance;
- (13) The Labor Commissioner may make complaint to the prosecuting authorities regarding any employer or agent of the employer, or officer or agent of the corporation who files a false certified payroll with respect to the status of an employee who is performing manual labor on a public building construction project;
- (14) The statute provides the minimum standards required for the completion of a safety course by manual laborers on public construction contracts; any contractor can exceed these minimum requirements; and
- (15) Regulations clarifying the statute are currently in the regulatory process, and shall be posted on the CTDOL website as soon as they are adopted in final form.
- (16) Any questions regarding this statute may be directed to the Wage and Workplace Standards Division of the Connecticut Labor Department via the internet website of <http://www.ctdol.state.ct.us/wgwkstnd/wgemenu.htm>; or by telephone at (860)263-6790.

THE ABOVE INFORMATION IS PROVIDED EXCLUSIVELY AS AN EDUCATIONAL RESOURCE, AND IS NOT INTENDED AS A SUBSTITUTE FOR LEGAL INTERPRETATIONS WHICH MAY ULTIMATELY ARISE CONCERNING THE CONSTRUCTION OF THE STATUTE OR THE REGULATIONS.

November 29, 2006

Notice
To All Mason Contractors and Interested Parties
Regarding Construction Pursuant to Section 31-53 of the
Connecticut General Statutes (Prevailing Wage)

The Connecticut Labor Department Wage and Workplace Standards Division is empowered to enforce the prevailing wage rates on projects covered by the above referenced statute.

Over the past few years the Division has withheld enforcement of the rate in effect for workers who operate a forklift on a prevailing wage rate project due to a potential jurisdictional dispute.

The rate listed in the schedules and in our Occupational Bulletin (see enclosed) has been as follows:

Forklift Operator:

- **Laborers (Group 4) Mason Tenders** - operates forklift solely to assist a mason to a maximum height of nine feet only.
- **Power Equipment Operator (Group 9)** - operates forklift to assist any trade and to assist a mason to a height over nine feet.

The U.S. Labor Department conducted a survey of rates in Connecticut but it has not been published and the rate in effect remains as outlined in the above Occupational Bulletin.

Since this is a classification matter and not one of jurisdiction, effective January 1, 2007 the Connecticut Labor Department will enforce the rate on each schedule in accordance with our statutory authority.

Your cooperation in filing appropriate and accurate certified payrolls is appreciated.

Information Bulletin ***Occupational Classifications***

The Connecticut Department of Labor has the responsibility to properly determine "job classification" on prevailing wage projects covered under C.G.S. Section 31-53(d).

Note: This information is intended to provide a sample of some occupational classifications for guidance purposes only. It is not an all-inclusive list of each occupation's duties. This list is being provided only to highlight some areas where a contractor may be unclear regarding the proper classification. If unsure, the employer should seek guidelines for CTDOL.

Below are additional clarifications of specific job duties performed for certain classifications:

- **ASBESTOS WORKERS**

Applies all insulating materials, protective coverings, coatings and finishes to all types of mechanical systems.

- **ASBESTOS INSULATOR**

Handle, install apply, fabricate, distribute, prepare, alter, repair, dismantle, heat and frost insulation, including penetration and fire stopping work on all penetration fire stop systems.

- **BOILERMAKERS**

Erects hydro plants, incomplete vessels, steel stacks, storage tanks for water, fuel, etc. Builds incomplete boilers, repairs heat exchanges and steam generators.

- **BRICKLAYERS, CEMENT MASONS, CEMENT FINISHERS, MARBLE MASONS, PLASTERERS, STONE MASONS, PLASTERERS. STONE MASONS, TERRAZZO WORKERS, TILE SETTERS**

Lays building materials such as brick, structural tile and concrete cinder, glass, gypsum, terra cotta block. Cuts, tools and sets marble, sets stone, finishes concrete, applies decorative steel, aluminum and plastic tile, applies cements, sand, pigment and marble chips to floors, stairways, etc.

- **CARPENTERS, MILLWRIGHTS. PILEDRIVERMEN. LATHERS. RESILEINT FLOOR LAYERS, DOCK BUILDERS, DIKERS, DIVER TENDERS**

Constructs, erects, installs and repairs structures and fixtures of wood, plywood and wallboard. Installs, assembles, dismantles, moves industrial machinery. Drives piling into ground to provide foundations for structures such as buildings and bridges, retaining walls for earth embankments, such as cofferdams. Fastens wooden, metal or rockboard lath to walls, ceilings and partitions of buildings, acoustical tile layer, concrete form builder. Applies firestopping materials on fire resistive joint systems only. Installation of curtain/window walls only where attached to wood or metal studs. Installation of insulated material of all types whether blown, nailed or attached in other ways to walls, ceilings and floors of buildings. Assembly and installation of modular furniture/furniture systems. Free-standing furniture is not covered. This includes free standing: student chairs, study top desks, book box desks, computer furniture, dictionary stand, atlas stand, wood shelving, two-position information access station, file cabinets, storage cabinets, tables, etc.

- **LABORER, CLEANING**

- The clean up of any construction debris and the general (heavy/light) cleaning, including sweeping, wash down, mopping, wiping of the construction facility and its furniture, washing, polishing, and dusting.

- **DELIVERY PERSONNEL**

- If delivery of supplies/building materials is to one common point and stockpiled there, prevailing wages are not required. If the delivery personnel are involved in the distribution of the material to multiple locations within the construction site then they would have to be paid prevailing wages for the type of work performed: laborer, equipment operator, electrician, ironworker, plumber, etc.

- An example of this would be where delivery of drywall is made to a building and the delivery personnel distribute the drywall from one "stockpile" location to further sub-locations on each floor. Distribution of material around a construction site is the job of a laborer or tradesman, and not a delivery personnel.

- **ELECTRICIANS**

Install, erect, maintenance, alteration or repair of any wire, cable, conduit, etc., which generates, transforms, transmits or uses electrical energy for light, heat, power or other purposes, including the Installation or maintenance of telecommunication, LAN wiring or computer equipment, and low voltage wiring. ***License required per Connecticut General Statutes: E-1,2 L-5,6 C-5,6 T-1,2 L-1,2 V-1,2,7,8,9.**

- **ELEVATOR CONSTRUCTORS**

Install, erect, maintenance and repair of all types of elevators, escalators, dumb waiters and moving walks. **License required by Connecticut General Statutes: R-1,2,5,6.*

- **FORK LIFT OPERATOR**

Laborers Group 4) Mason Tenders - operates forklift solely to assist a mason to a maximum height of nine (9) feet only.

Power Equipment Operator Group 9 - operates forklift to assist any trade, and to assist a mason to a height over nine (9) feet.

- **GLAZIERS**

Glazing wood and metal sash, doors, partitions, and 2 story aluminum storefronts. Installs glass windows, skylights, store fronts and display cases or surfaces such as building fronts, interior walls, ceilings and table tops and metal store fronts. Installation of aluminum window walls and curtain walls is the "joint" work of glaziers and ironworkers, which require equal composite workforce.

- **IRONWORKERS**

Erection, installation and placement of structural steel, precast concrete, miscellaneous iron, ornamental iron, metal curtain wall, rigging and reinforcing steel. Handling, sorting, and installation of reinforcing steel (rebar). Metal bridge rail (traffic), metal bridge handrail, and decorative security fence installation. Installation of aluminum window walls and curtain walls is the "joint" work of glaziers and ironworkers which require equal composite workforce.

- **INSULATOR**

- Installing fire stopping systems/materials for "Penetration Firestop Systems": transit to cables, electrical conduits, insulated pipes, sprinkler pipe penetrations, ductwork behind radiation, electrical cable trays, fire rated pipe penetrations, natural polypropylene, HVAC ducts, plumbing bare metal, telephone and communication wires, and boiler room ceilings.

- **LABORERS**

Acetylene burners, asphalt rakers, chain saw operators, concrete and power buggy operator, concrete saw operator, fence and guard rail erector (except metal bridge rail (traffic), decorative security fence (non-metal).

installation.), hand operated concrete vibrator operator, mason tenders, pipelayers (installation of storm drainage or sewage lines on the street only), pneumatic drill operator, pneumatic gas and electric drill operator, powermen and wagon drill operator, air track operator, block paver, curb setters, blasters, concrete spreaders.

- **PAINTERS**

Maintenance, preparation, cleaning, blasting (water and sand, etc.), painting or application of any protective coatings of every description on all bridges and appurtenances of highways, roadways, and railroads. Painting, decorating, hardwood finishing, paper hanging, sign writing, scenic art work and drywall hhg for any and all types of building and residential work.

- **LEAD PAINT REMOVAL**

- Painter's Rate

1. Removal of lead paint from bridges.
2. Removal of lead paint as preparation of any surface to be repainted.
3. Where removal is on a Demolition project prior to reconstruction.

- Laborer's Rate

1. Removal of lead paint from any surface NOT to be repainted.
2. Where removal is on a *TOTAL* Demolition project only.

- **PLUMBERS AND PIPEFITTERS**

Installation, repair, replacement, alteration or maintenance of all plumbing, heating, cooling and piping. **License required per Connecticut General Statutes: P-1,2,6,7,8,9 J-1,2,3,4 SP-1,2 S-1,2,3,4,5,6,7,8 B-1,2,3,4 D-1,2,3,4.*

- **POWER EQUIPMENT OPERATORS**

Operates several types of power construction equipment such as compressors, pumps, hoists, derricks, cranes, shovels, tractors, scrapers or motor graders, etc. Repairs and maintains equipment. **License required, crane operators only, per Connecticut General Statutes.*

- **ROOFERS**

Covers roofs with composition shingles or sheets, wood shingles, slate or asphalt and gravel to waterproof roofs, including preparation of surface. (demolition or removal of any type of roofing and or clean-up of any and all areas where a roof is to be relaid.)

- **SHEETMETAL WORKERS**

Fabricate, assembles, installs and repairs sheetmetal products and equipment in such areas as ventilation, air-conditioning, warm air heating, restaurant equipment, architectural sheet metal work, sheetmetal roofing, and aluminum gutters. Fabrication, handling, assembling, erecting, altering, repairing, etc. of coated metal material panels and composite metal material panels when used on building exteriors and interiors as soffits, fascia, louvers, partitions, canopies, cornice, column covers, awnings, beam covers, cladding, sun shades, lighting troughs, spires, ornamental roofing, metal ceilings, mansards, copings, ornamental and ventilation hoods, vertical and horizontal siding panels, trim, etc. The sheet metal classification also applies to the vast variety of coated metal material panels and composite metal material panels that have evolved over the years as an alternative to conventional ferrous and non-ferrous metals like steel, iron, tin, copper, brass, bronze, aluminum, etc. Fabrication, handling, assembling, erecting, altering, repairing, etc. of architectural metal roof, standing seam roof, composite metal roof, metal and composite bathroom/toilet partitions, aluminum gutters, metal and composite lockers and shelving, kitchen equipment, and walk-in coolers. To include testing and air –balancing ancillary to installation and construction.

- **SPRINKLER FITTERS**

Installation, alteration, maintenance and repair of fire protection sprinkler systems.

****License required per Connecticut General Statutes: F-1,2,3,4.***

- **TILE MARBLE AND TERRAZZO FINISHERS**

Assists and tends the tile setter, marble mason and terrazzo worker in the performance of their duties.

- **TRUCK DRIVERS**

~How to pay truck drivers delivering asphalt is under REVISION~

Truck Drivers are requires to be paid prevailing wage for time spent "working" directly on the site. These drivers remain covered by the prevailing wage for any time spent transporting between the actual construction location and facilities (such as fabrication, plants, mobile factories, batch plant, borrow pits, job headquarters, tool yards, etc.) dedicated exclusively, or nearly so, to performance of the contract or project, which are so located in proximity to the actual construction location that it is reasonable to include them. ****License required, drivers only, per Connecticut General Statutes.***

For example:

- Material men and deliverymen are not covered under prevailing wage as long as they are not directly involved in the construction process. If, they unload the material, they would then be covered by prevailing wage for the classification they are performing work in: laborer, equipment operator, etc.
- Hauling material off site is not covered provided they are not dumping it at a location outlined above.
- Driving a truck on site and moving equipment or materials on site would be considered covered work, as this is part of the construction process.

➤ *Any questions regarding the proper classification should be directed to:*
Public Contract Compliance Unit
Wage and Workplace Standards Division
Connecticut Department of Labor
200 Folly Brook Blvd, Wethersfield, CT 06109
(860) 263-6543.

**Connecticut Department of Labor
Wage and Workplace Standards Division
FOOTNOTES**

⇒ Please Note: If the “Benefits” listed on the schedule for the following occupations includes a letter(s) (+ a or + a+b for instance), refer to the information below.

Benefits to be paid at the appropriate prevailing wage rate for the listed occupation.

If the “Benefits” section for the occupation lists only a dollar amount, disregard the information below.

**Bricklayers, Cement Masons, Cement Finishers, Concrete Finishers, Stone Masons
(Building Construction) and
(Residential- Hartford, Middlesex, New Haven, New London and Tolland Counties)**

- a. Paid Holiday: Employees shall receive 4 hours for Christmas Eve holiday provided the employee works the regularly scheduled day before and after the holiday. Employers may schedule work on Christmas Eve and employees shall receive pay for actual hours worked in addition to holiday pay.

Elevator Constructors: Mechanics

- a. Paid Holidays: New Year’s Day, Memorial Day, Independence Day, Labor Day, Veterans’ Day, Thanksgiving Day, Christmas Day, plus the Friday after Thanksgiving.
- b. Vacation: Employer contributes 8% of basic hourly rate for 5 years or more of service or 6% of basic hourly rate for 6 months to 5 years of service as vacation pay credit.

Glaziers

- a. Paid Holidays: Labor Day and Christmas Day.

**Power Equipment Operators
(Heavy and Highway Construction & Building Construction)**

- a. Paid Holidays: New Year’s Day, Good Friday, Memorial day, Independence Day, Labor Day, Thanksgiving Day and Christmas Day, provided the employee works 3 days during the week in which the holiday falls, if scheduled, and if scheduled, the working day before and the working day after the holiday. Holidays falling on Saturday may be observed on Saturday, or if the employer so elects, on the preceding Friday.

Ironworkers

- a. Paid Holiday: Labor Day provided employee has been on the payroll for the 5 consecutive work days prior to Labor Day.

Laborers (Tunnel Construction)

- a. Paid Holidays: New Year's Day, Memorial Day, Independence Day, Labor Day, Thanksgiving Day and Christmas Day. No employee shall be eligible for holiday pay when he fails, without cause, to work the regular work day preceding the holiday or the regular work day following the holiday.

Roofers

- a. Paid Holidays: July 4th, Labor Day, and Christmas Day provided the employee is employed 15 days prior to the holiday.

Sprinkler Fitters

- a. Paid Holidays: Memorial Day, July 4th, Labor Day, Thanksgiving Day and Christmas Day, provided the employee has been in the employment of a contractor 20 working days prior to any such paid holiday.

Truck Drivers

(Heavy and Highway Construction & Building Construction)

- a. Paid Holidays: New Year's Day, Memorial Day, Independence Day, Labor Day, Thanksgiving Day, Christmas day, and Good Friday, provided the employee has at least 31 calendar days of service and works the last scheduled day before and the first scheduled day after the holiday, unless excused.

PROJECT MANUAL

for

CITY OF MERIDEN First Floor New Air Conditioning System at

**ROGER SHERMAN
Elementary School
64 N Pearl Street
Meriden, CT 06450**

**Bemis Associates LLC
185 Main Street
Farmington, Connecticut 06032**

November 10th, 2023

**CITY OF MERIDEN BOARD OF EDUCATION
ROGER SHERMAN ELEMENTARY SCHOOL
FIRST FLOOR NEW AIR CONDITIONING SYSTEM
MERIDEN, CONNECTICUT**

SECTION 20 00 50 - GENERAL CONDITIONS FOR MECHANICAL AND ELECTRICAL SYSTEMS

PART 1 - GENERAL

1.1 RELATED DOCUMENTS:

- A. The General provisions of the Contract, including General and Supplementary Conditions, General Requirements apply to the work specified in this Section.
- B. Scope of Work: This Section contains special provisions for Divisions 23 and 26.

1.2 EXAMINATION OF SITE AND DRAWINGS:

- A. Before submitting his bid, Contractor shall visit site with plans and specifications in hand, shall consult with the Engineer and shall become thoroughly familiar with all conditions under which his work will be done since he will be held responsible for any assumptions he may make in regard thereto.
- B. The Contractor shall verify and obtain all necessary dimensions at the building.
- C. Certain present building clearances are available for handling equipment. All equipment shall be delivered knocked down as necessary to clear restrictions.

1.3 INTENT:

- A. Finished Work: The intent of the specifications and drawings is to call for finished work, completed, tested and ready for operation.
- B. Good Practice: It is not intended that the drawings show every pipe, fitting or minor detail and it is understood that while the drawings must be followed as closely as circumstances will permit, the systems shall be installed according to the intent and meaning of the Contract Documents and in accordance with good practice.
- C. Work under each Section shall include giving written notice to the Owner within 15 days after the Award of the Contract of any materials of apparatus believed inadequate or unsuitable or in violation of any laws or codes, or items of work omitted. In the absence of such written notice, it is mutually agreed that work under each Section has included the cost of all required items and labor for the satisfactory functioning of the entire system without extra compensation.
- D. Any apparatus, appliance, material or work not shown on drawings but mentioned in specifications or vice versa, or any incidental accessories necessary to make the work complete and perfect in all respects and ready for operation, even if not particularly specified, shall be furnished and installed by Contractor at no additional cost to Owner.
- E. Prior to receipt of bids, Contractors shall give written notice to Engineer of any materials or apparatus believed inadequate, unsuitable or in violation of laws, ordinances, rules or regulations of authorities having jurisdiction and any necessary items or work omitted.

**CITY OF MERIDEN BOARD OF EDUCATION
ROGER SHERMAN ELEMENTARY SCHOOL
FIRST FLOOR NEW AIR CONDITIONING SYSTEM
MERIDEN, CONNECTICUT**

In the absence of such written notice, it is mutually agreed that Contractor has included the cost of all required items in his proposal and that he will be responsible for approved satisfactory functioning of systems without further compensation.

- F. In all cases where apparatus is herein referred to in singular number, it is intended that such reference include as many such items as are required to complete work.
- G. If not otherwise specified or shown on plans, apparatus and materials shall be installed in accordance with manufacturer's published recommendations and instructions and to the complete satisfaction of the Architect.
- H. It is the intent of these specifications for Mechanical and Electrical Contractors and/or their subcontractors or equipment suppliers to furnish all equipment complete with all accessories.

1.4 REGULATIONS:

- A. Codes: All work shall be done in strict accordance with the 2022 Connecticut State Building Code, 2022 Connecticut State Fire Safety Code, 2021 IBC, 2021 IPC, 2021 IMC, Connecticut Public Health Code, 2021 NFPA 101, all applicable NFPA Codes, NEC, UL, NEMA, O.S.H.A., with all requirements of local utility companies and the requirements of all governmental departments having jurisdiction.
- B. Precedence: Requirements of the above shall take precedence over plans and specifications.
- C. Equipment construction standards shall be as follows: Pressure vessels shall be constructed in accordance with the ASME Code, all electrical equipment shall be UL listed and approved and conform to the N.E.C., gas equipment shall be approved by A.G.A. and conform to N.F.P.A. Codes, piping materials, fittings, valves and accessories shall be constructed in accordance with A.S.T.M. and A.N.S.I. standards for class of work involved. All equipment and materials shall be new and of domestic manufacture. All the above codes shall be referenced and dated in the Connecticut Basic Building Code.
- D. Wherever discrepancies occur between above regulations and agencies and contract drawings and specifications, the requirements of above shall take precedence, except that the contract drawings and specifications shall be minimum requirements and that contractors shall advise engineer of any required changes before proceeding with work.

1.5 APPROVED FITTINGS:

- A. No material other than that contained in the "Latest List of Electric Fittings" approved by the Underwriters' Laboratories, Inc., shall be used in any part of the work. All wiring, conduit, switches and other material for which label service has been established, shall bear the label of the Underwriters' Laboratories, Inc.

1.6 PERMITS, FEES:

- A. Include all necessary notices, obtain all permits and pay all governmental taxes, fees, and other costs. File all necessary plans, prepare all documents and obtain all necessary approvals of all governmental departments having jurisdiction. Obtain all required Certificates of the Owner before request for acceptance and final payment for the work.

**CITY OF MERIDEN BOARD OF EDUCATION
ROGER SHERMAN ELEMENTARY SCHOOL
FIRST FLOOR NEW AIR CONDITIONING SYSTEM
MERIDEN, CONNECTICUT**

1.7 DEFINITIONS:

- A. Words "finish" or "finished" refer to all rooms and areas listed in Finished Schedule on Architect's Drawings. All rooms and areas not covered in Schedule, including underground tunnels and areas above ceilings, shall be considered not finished except as otherwise noted.
- B. The word "provide" means to "furnish and install" reference item.

1.8 PROTECTION:

- A. Work under each section shall include protecting the work and materials of all other sections from damage by work or workmen, and shall include making good any and all damage thus caused.
- B. Each section shall be responsible for work and equipment until finally inspected, tested and accepted. Protect work against theft, weather, injury or damage and carefully store material and equipment received on site which is not immediately installed. Close open ends of work with temporary covers or plugs during construction to prevent entry of obstructing materials.
- C. If so specified under the respective section, work may include receiving, unloading, uncrating, storing, protecting, setting in place and connecting up completely of any motor starters, control equipment having mechanical/electrical service connections which may be furnished by Owner or furnished under another section.

Work under each section shall include exercising special care in handling and protecting equipment and fixtures. Any of the above equipment and fixtures which are missing or damaged by reason of mishandling or failure to protect shall be replaced at no additional cost to the Owner.

1.9 EQUIPMENT SUBSTITUTIONS AND DEVIATIONS:

- A. Wherever more than one manufacturer is mentioned in specifications and drawings, any of these named are considered equally acceptable to that on upon which design was based and, providing all requirements are met, insofar as performance, space requirements, noise levels and special accessories or materials are concerned, any of those named may be included in Contractor's bid.
- B. Where Contractor proposes to use an item of equipment which differs from that upon which design was based, which required any redesign of structure, partitions, foundations, piping, wiring or of any other part of Mechanical, Electrical or Architectural Layout, all such redesign, new drawings or detailing required shall be prepared by Contractor at his own expense for approval of Engineer.
- C. Where approved substitutions or deviations require a different quantity, size or arrange of structural supports, wiring, conduit, piping, ductwork, and equipment from that upon which design was based, all additional items required by the systems shall, with the approval of Engineer, be furnished by Contractor at no additional cost to Owner.

**CITY OF MERIDEN BOARD OF EDUCATION
ROGER SHERMAN ELEMENTARY SCHOOL
FIRST FLOOR NEW AIR CONDITIONING SYSTEM
MERIDEN, CONNECTICUT**

1.10 ELECTRICAL WORK:

- A. The Electrical Section includes all power wiring for all electrical switches, motor starters and unmounted motors, furnished at the job site by other sections or furnished under the Electrical Sections as stated in other sections of the specifications.
- B. The Electrical Section shall install and wire all starters, switches and controls, as specified and/or shown on drawings. This shall include all operating and safety controls.
- C. Electrically operated equipment supplied by other sections which will be installed and wired by Electrical Section shall be delivered to him with detailed instructions for their installation and wiring in sufficient time and proper sequence to enable him to meet his work schedule.
- D. Control devices that include mechanical elements, such as float switches, shall be installed by the section furnishing them, but be wired by the Electrical Sections.
- E. Equipment which includes a number of correlated electrical control devices mounted in a single enclosure or on a common base with equipment shall be supplied for installation completely wired as unit with terminal boxes and ample leads and/or terminal strips, ready for electrical wiring.
- F. Electrical Contractor shall furnish local disconnect switch for all equipment and manual motor starter for fractional HP motors.

1.11 DRAWINGS:

- A. The mechanical and electrical drawings are intended to supplement each other and are to be considered as a unit which, taken together in conjunction with the specifications, completely describes the work to be done. All drawings shall be checked to verify spaces in which work will be installed. Where headroom or space conditions appear inadequate, notification shall be given to Engineer before proceeding with installation.
- B. The Engineer may without charge, make modifications in the layout as needed to prevent conflict with work of other trades or for proper execution of the work.
- C. Note that the drawings are diagrammatic and indicate the general arrangement of the Mechanical and Electrical Equipment and systems, without showing every detail and fitting.
- D. Where conflicts occur between drawings and specifications or within either, the item or arrangement of better quality, greater quality or highest cost shall be included in Contract price. Engineer shall determine the manner or item with which work shall be installed.
- E. Keep one complete set of all drawings, specifications, shop drawings and addenda on the premises at all times in good condition and available to the Engineer and Owner.

1.12 REVIEWS:

- A. The materials, workmanship, design and arrangement of all work installed under the Mechanical and Electrical sections shall be subject to the review of the Engineer.

**CITY OF MERIDEN BOARD OF EDUCATION
ROGER SHERMAN ELEMENTARY SCHOOL
FIRST FLOOR NEW AIR CONDITIONING SYSTEM
MERIDEN, CONNECTICUT**

- B. Where any specific material process of method of construction or manufactured article is specified by name or by reference to the catalog number of a manufacturer, the specifications are to be used as a guide and not intended to take precedence over the basic duty and performance specified or noted on drawings. In all cases, the specific characteristics of the equipment offered for approval, shall be indicated on the shop drawings.
- C. All component parts of each item of equipment or device shall bear the manufacturer's nameplate, giving name of manufacturer, description, size, type, serial or model number, electrical characteristics, etc. in order to facilitate maintenance or replacement. The nameplate of a subcontractor or distributor will not be acceptable.
- D. If material or equipment is installed before it is reviewed, it shall be removed and replaced at no extra charge to the Owner if, in the opinion of the Engineer, the material or equipment does not meet the intent of the drawings and specifications.

1.13 SHOP DRAWINGS:

- A. Contractor shall submit for review electronic shop drawings of all new equipment, materials, piping, lighting fixtures, devices, panels, wiring and reports. Engineer's review of shop drawings must be completed before any equipment is purchased or any work is installed.
- B. Shop drawings shall consist of manufacturer's certified scale drawings, cuts or catalog, including descriptive literature and complete certified characteristics of equipment, showing dimensions, capacity, code requirements, motor and drive testing as indicated on the drawings or specifications. Also, sheet metal fabrication drawings drawn to scale of 1/4" to the foot or larger.
- C. Certified performance curves for all pumping equipment shall be submitted for review.
- D. Samples, drawings, specifications, catalogs, etc. submitted for review shall be properly labeled indicating specific service for which material or equipment is to be used, division and article number of specifications governing Contractor's name and name of job.
- E. Catalog, pamphlets or other documents submitted to describe items on which review is being requested, shall be specific and identification in catalog, pamphlet, etc. of item submitted shall be clearly made in ink. Data of a general nature will not be accepted.
- F. Review stamp rendered on shop drawings shall not be considered as a guarantee of measurements of building conditions. Where drawings are reviewed, said review does not mean that drawings have been checked in detail. Said review does not in any way relieve the Contractor from his responsibility or necessity of furnishing material or performing work as required by the Contract Drawings and Specifications.
- G. Failure by the Contractor to submit shop drawings in ample time for checking shall not entitle him to an extension of Contract and no claim for extension by reason of such default will be allowed.
- H. Prior to submission of shop drawings, the Contractor shall thoroughly check each shop drawing, reject those not conforming to the specifications and indicate by his signature that the shop drawings submitted in his opinion meet Contract requirements.

**CITY OF MERIDEN BOARD OF EDUCATION
ROGER SHERMAN ELEMENTARY SCHOOL
FIRST FLOOR NEW AIR CONDITIONING SYSTEM
MERIDEN, CONNECTICUT**

1.14 CUTTING AND PATCHING:

- A. Cutting and patching shall be done in accordance with Division 01, section 017329 unless otherwise specified.
- B. The General Contractor will leave all openings and built-in sleeves, etc. as required, provided he receive same with the proper information and cooperation from the Electrical and/or Mechanical Contractor in due time as the construction progresses.
All cutting of openings in walls, floors, partitions, etc. not thus provided for must, however, be done by the Electrical and/or Mechanical Contractor as required to install the work including all cutting of existing construction work, and this Contractor shall restore to its original condition any work disturbed.

PART 2 - PRODUCTS

2.1 MATERIALS AND WORKMANSHIP:

- A. All materials and apparatus used shall be new, of first class quality and shall be furnished, delivered, erected, connected and finished in every detail. No materials or apparatus used shall be discontinued or about to be discontinued items.
- B. The Engineer shall have the right to reject any part of the work in case material or workmanship is not of satisfactory quality.
- C. Any unacceptable work and material shall be replaced with acceptable work and material at no additional expense to the Owner.
- D. In case there is any doubt of the acceptability of any material, submit samples to the Engineer for approval and only definite approval in writing from the Engineer shall be evidence of such approval. Such approval shall also be subject to the satisfactory installation of the material.
- E. The work in each of these sections shall be constantly under the direction of a competent superintendent who shall be on the premises during such period as the work is in progress. The superintendent shall familiarize himself with the work of all other sections involved insofar as they relate to or in any way affect the work of these sections, and shall coordinate the work.
- F. Unless otherwise noted, all equipment and materials shall be installed and/or applied in accordance with the recommendations of the manufacturer of said equipment, including the performance of any tests recommended by the manufacturer.

2.2 EQUIPMENT VARIATIONS:

- A. In these specifications and on the accompanying drawings, one or more makes of materials, apparatus or appliances have been specified for use in this installation. This has been done for convenience in fixing the standard of workmanship performance of any materials, apparatus or appliance which shall be substituted for those mentioned herein shall also conform to these standards.

**CITY OF MERIDEN BOARD OF EDUCATION
ROGER SHERMAN ELEMENTARY SCHOOL
FIRST FLOOR NEW AIR CONDITIONING SYSTEM
MERIDEN, CONNECTICUT**

- B. Where no specified make or material, apparatus or appliance is mentioned, any first class product made by a reputable manufacturer may be used, providing it conforms to the requirements of these specifications and meets the approval of the Engineer.
- C. Refer to General Conditions of the contract for substitution procedures.
- D. To substitute other makes of materials, apparatus or appliance, than those mentioned under the mechanical or electrical sections, a request in writing to be allowed to make the substitution shall be made. This request shall be accompanied by complete plans and specifications of the substitution offered. If so requested by the Architect or Engineer, also submit samples of both the specified material or appliance and the substitute.

2.3 ACCESS DOORS:

- A. Access doors shall be of sufficient size to permit easy replacement of complete units and all groupings of complete units and all groupings of valves and equipment shall have necessary clearance for this same purpose. Provide access doors for each valve, damper, control, fire damper, etc., not accessible (such as above a non-lift out ceiling, wall or chase). Doors shall be Milcor or equal prime coated steel, screwdriver lock for building into walls or ceilings. Doors shall be Style A in acoustic tile surfaces and Styles K, L or M for other surfaces. Doors shall bear the same or greater fire rating as the wall or ceiling in which they occur. Size of doors to be determined after valves or dampers are installed and shall be of adequate size to operate same.
- B. Where access is required to dampers, valves, etc., that occur above lay-in ceilings, these access doors can be omitted, provided suitable plastic markers identifying exact location of valves, dampers, etc., on lay-in ceilings are applied directly below valve grouping and identified by a number, this number to be used as a marking on valve or damper chart. Tags shall be applied on the ceiling grid, not on the ceiling tiles.

PART 3 - EXECUTION

3.1 CONNECTING TO EXISTING UTILITIES:

- A. Connections to existing utilities that will interrupt the service to the present buildings shall be made at a time agreed upon by the Owner, Architect and Contractor.
- B. If it is necessary to make connections to existing utilities outside the regular working hours, this shall be noted on the written work order and the respective Contractor will be paid for the additional cost of labor over and above what it would cost at regular day time rates.

3.2 FREIGHT, CARTING AND RIGGING:

- A. Contractor shall pay all freight and carting charges necessary to deliver all equipment furnished under his Contract to the site and furnish all necessary rigging to properly rig and set the apparatus on the foundations, frames, etc.
- B. All scaffolding, blocks and tackle, ropes and chains and other equipment necessary to rig and set the apparatus shall be furnished by the Contractor.
- C. The Contractor shall set, level and align all equipment before starting operations.

**CITY OF MERIDEN BOARD OF EDUCATION
 ROGER SHERMAN ELEMENTARY SCHOOL
 FIRST FLOOR NEW AIR CONDITIONING SYSTEM
 MERIDEN, CONNECTICUT**

3.3 SEISMIC RESTRAINTS:

- A. It is the intent of this seismic restraint portion of the specification to provide restraint of all non-structural building system components provided in Sections 15 and 16 in Seismic Zone II. Restraint systems and devices are intended to withstand, without failure, the "G" forces detailed in the chart below:

Design Level of Acceleration At Equipment Center of Gravity Seismic Zone 2)
 (Av - >0.1 to 0.19)

Elevation (feet rel. to grade level)	Rigid* Mnt'd Equip	Non-Struct. Architect Component	Flexible* Mnt'd Equip	Pipe, Duct, Cable trays, Conduit, Etc.	Life Safe. Equip
Below Grade up to 20 feet above grade	0.125 "g"	0.250 "g"	0.500 "g"	0.350 "g"	1.000 "g"
21 ft. - 300 ft.	0.500 "g"	0.550 "g"	0.750 "g"	0.650 "g"	1.000 "g"
301 ft. - 600 ft.	0.750 "g"	0.900 "g"	1.000 "g"	1.000 "g"	1.000 "g"

* Rigid mounted equipment is any equipment mounted directly to structure. Flexible mounted equipment is any equipment mounted on resilient supports, ceiling suspended, roof supported or mounted on an independent frame with any primary natural frequency below 16 Hz.

- B. Seismic restraints shall be as required by the 2016 Connecticut Building Code.
- C. Refer to section 220548 and drawings for details.
- D. Seismic Certification and Analysis
1. Seismic restraint calculations must be provided for all connections of equipment to the structure.
 2. Calculations to support seismic restraint designs must be stamped by a registered professional engineer licensed in the State of Connecticut.
 3. Analysis must indicate dead loads, derived loads, and materials used for connections to equipment and structure. Analysis must detail anchoring methods, bolt diameters, embedment, and weld length.
 4. A seismic design errors and omissions insurance certificate must accompany submittals.
- E. Submit drawings showing locations of all seismic restraints for equipment, piping, and conduit provided under Sections 21, 22, 23, 26, 27 and 28.
1. The term EQUIPMENT includes ALL non-structural components. These specifications are applicable within the facility and 5 feet outside of the foundation wall. Equipment buried underground is excluded but entry of services through the foundation wall is included.

**CITY OF MERIDEN BOARD OF EDUCATION
ROGER SHERMAN ELEMENTARY SCHOOL
FIRST FLOOR NEW AIR CONDITIONING SYSTEM
MERIDEN, CONNECTICUT**

Equipment referred to below is a partial list; (equipment not listed is still included in this specification).

AC Units	Condensing Unit
Conduit	All Electrical Panels

- F. Submittals shall include a listing of all isolated and non-isolated equipment to be restrained.
- G. Seismic restraints shall not be required for the following installations:
1. Piping in mechanical rooms less than 1 1/4-inch inside diameter.
 2. All other piping less than 2 1/2-inch inside diameter.
 3. All electrical conduit less than 2 1/2-inch inside diameter.
 4. All rectangular air-handling ducts less than 6 square feet in cross-sectional area.
 5. All round air-handling ducts less than 28 inches in diameter.
 6. All piping suspended by individual hangers 12 inches or less in length from the top of the pipe to the bottom of the support for the hanger.
 7. All ducts suspended by hangers 12 inches or less in length from the top of the duct to the bottom of the support for the hanger.
- H. Life safety systems defined:
1. All systems involved with fire protection including sprinkler piping, service water supply piping, fire dampers and smoke exhaust systems.
 2. All systems involved with and/or connected to emergency power supply including all generators, transfer switches, transformers and all flow paths to fire protection and/or emergency lighting systems.
 3. Fresh air relief systems on emergency control sequence including air handlers, conduit, duct, dampers, etc.

3.4 COOPERATION WITH OTHER TRADES:

- A. No piping, ducts, conduit, valves, boxes, etc., shall be installed until the entire run has been checked for clearance and the work has been coordinated between all the trades. Each tradesman shall be responsible for taking his own field measurements and maintaining proper clearance from the Owner's equipment and the work of other trades, and for coordinating his work with that of other Contractors and Owner. Furnish all necessary information, dimensions, templates, etc. in order that a perfectly coordinated job will result.
- B. Contractor shall carry out his work in conjunction with other trades and shall give full cooperation to other trades. Contractor shall furnish all information necessary to permit work of all trades to be installed in a satisfactory manner.
- C. Where space is so limited that Contractor's work shall be installed in close proximity to the work of other trades or where it is evident that Contractor's work will interfere with other trades, he shall assist in working out space conditions to make satisfactory adjustments. If required or directed by Engineer, the Contractor shall prepare composite working drawings and sections of not less than 3/4" -1'-0" scale clearly showing how his work is to be installed in conjunction with other trades; he shall make corrections necessary to satisfactorily complete installation at no additional cost to Owner.

**CITY OF MERIDEN BOARD OF EDUCATION
ROGER SHERMAN ELEMENTARY SCHOOL
FIRST FLOOR NEW AIR CONDITIONING SYSTEM
MERIDEN, CONNECTICUT**

- D. All supports for hanging material to be connected to steel structure shall be installed prior to installation of fire proofing material. Refer to Division 7 of the specifications.
Any damage to fireproofing caused by late installation of hanging material shall be repaired by the Fire-proofing Contractor at the expense of the Contractor responsible.
- E. The Plumbing and Heating Contractors shall give to the Electrical Contractor all information on switches, controls, pilots, etc. furnished under the Plumbing and Heating Contracts, together with makes and catalog numbers where required to permit the Electrical Contractor to leave the proper boxes to receive same. This information shall be given well in advance so that the Electrical Contractor may install his work as construction progresses. In the event that this information is not given in time to permit the Electrical Contractor to leave proper boxes, etc. as construction progresses, it shall be the responsibility of the Contractor to pay all costs of cutting and patching construction required because of this neglect.

3.5 INFORMATION FOR ELECTRICAL CONTRACTOR:

- A. Deliver to the Electrical Contractor all information on motors and controls furnished under the Mechanical Contract, together with makes and catalog numbers, to permit the Electrical Contractor to leave the proper boxes and wiring.
- B. Each electric motor of 1/2 h.p. or more shall be furnished with an automatic starter.
- C. Starters shall be furnished in type to be remotely controlled and fed from dual voltage transformer 208/460 120 volts.
- D. Starters to have overload and undervoltage protection. Starters shall be of the combination disconnect switch and starter type.

3.6 SLEEVES, INSERTS AND ANCHOR BOLTS:

- A. All pipes and conduits passing through floors, walls or partitions shall be provided with sleeves sized to give a minimum of 1/2" clearance between sleeve and the outside diameter of the pipe, conduit or insulation, enclosing the pipe or conduit.
- B. Sleeves through concrete floors or interior masonry walls shall be Schedule 40 steel pipe, set flush with finished wall or ceiling surfaces, but extending 2 inches above finished floors or shall be in accordance with details on drawings.

In all mechanical equipment rooms or penthouses, sleeves shall extend 6 inches above finished floor.

- C. Inserts shall be individual or strip type of steel or malleable iron construction for removable nuts and threaded rods up to 3/4" diameter, permitting lateral adjustment.
- D. Provide escutcheons on all pipes and conduits wherever they pass through floors, ceilings, walls, or partitions in finished areas. Escutcheons for pipes passing through floors shall be RITTER PATTERN AND CASTING COMPANY, No. 36A or approved equal split-hinged, cast brass type designated to fit pipe on one end and cover alcove projecting through floor on the other end.

**CITY OF MERIDEN BOARD OF EDUCATION
ROGER SHERMAN ELEMENTARY SCHOOL
FIRST FLOOR NEW AIR CONDITIONING SYSTEM
MERIDEN, CONNECTICUT**

Escutcheons for pipes shall be RITTER PATTERN AND CASTING COMPANY, No. 3A or approved equal - split-hinged, cast brass, chromium plated type.

3.7 FIRE STOPPING:

A. General

1. Firestopping: Material or combination of materials used to retain integrity of fire-rated construction by maintaining an effective barrier against the spread of flame, smoke, and hot gases through penetrations in fire rated wall and floor assemblies.

B. General Description of the Work : Only tested firestop systems shall be used in specific locations as follows: Penetrations for the passage of duct, cable, cable tray, conduit, piping, electrical busways and raceways through fire-rated vertical barriers (walls and partitions), horizontal barriers (floor/ceiling assemblies), and vertical service shaft walls and partitions.

C. References

1. Test Requirements: ASTM E-814, "Standard Method of Fire Tests of Through Penetration Fire Stops" (July 1997).
2. Underwriters Laboratories (UL) of Northbrook, IL runs ASTM E-814 under their designation of UL 1479 and publishes the results in their "FIRE RESISTANCE DIRECTORY" that is updated annually.
3. International Firestop Council Guidelines for Evaluating Firestop Systems Engineering Judgments
4. Test Requirements: ASTM E 84-96, "Surface burning characteristics".
5. All major building codes: ICBO, SBCCI, BOCA, and IBC.
6. Test Requirements: ASTM E-119, "Fire Test of Building Construction and Materials" (UL 263)

D. Quality Assurance

1. Firestop System installation must meet requirements of ASTM E-119, ASTM E-814, ASTM E-84-96, UL 236, UL 1479 or UL 2079 tested assemblies that provide a fire rating equal to that of construction being penetrated.
2. Firestop Systems do not reestablish the structural integrity of load bearing partitions/assemblies, or support live loads and traffic. Installer shall consult the structural engineer prior to penetrating any load bearing assembly.

E. Submittals

1. Submit Product Data: Manufacturer's specifications and technical data for each material including the composition and limitations, documentation of UL firestop systems to be used and manufacturer's installation instructions to comply with Section 013300.

**CITY OF MERIDEN BOARD OF EDUCATION
ROGER SHERMAN ELEMENTARY SCHOOL
FIRST FLOOR NEW AIR CONDITIONING SYSTEM
MERIDEN, CONNECTICUT**

2. Submit material safety data sheets provided with product delivered to job-site.

F. Installer Qualifications

1. Engage an experienced Installer who is certified, licensed, or otherwise qualified by the firestopping manufacturer as having been provided the necessary training to install manufacture's products per specified requirements.

G. Products, General

1. Provide firestopping composed of components that are compatible with each other, the substrates forming openings, and the items, if any, penetrating the firestopping under conditions of service and application, as demonstrated by the firestopping manufacturer based on testing and field experience.
2. Provide components for each firestopping system that are needed to install fill material. Use only components specified by the firestopping manufacturer and approved by the qualified testing agency for the designated fire-resistance-rated systems.
3. Firestopping Materials are either "cast-in-place" (integral with concrete placement) or "post installed." Provide cast-in-place firestop devices prior to concrete placement.

H. Acceptable Manufacturers

1. Subject to compliance with through penetration firestop systems (XHEZ) and joint systems (XHBN) listed in Volume II of the UL Fire Resistance Directory, provide products of the following manufacturers as identified below:
 - a. Hilti, Inc., Tulsa, Oklahoma 800-879-8000
 - b. Other manufacturers listed in the U.L. Fire Resistance Directory – Volume 2

I. Materials

1. Use only firestop products that have been UL 1479, ASTM E-814, or UL 2079 tested for specific fire-rated construction conditions conforming to construction assembly type, penetrating item type, annular space requirements, and fire-rating involved for each separate instance.
2. Provide a firestop system with a "F" Rating as determined by UL 1479 or ASTM E814 which is equal to the time rating of construction being penetrated.
3. Provide a firestop system with an Assembly Rating as determined by UL 2079 which is equal to the time rating of construction being penetrated.

J. Preparation

1. Verification of Conditions: Examine areas and conditions under which work is to be performed and identify conditions detrimental to proper or timely completion.

**CITY OF MERIDEN BOARD OF EDUCATION
ROGER SHERMAN ELEMENTARY SCHOOL
FIRST FLOOR NEW AIR CONDITIONING SYSTEM
MERIDEN, CONNECTICUT**

- a. Verify penetrations are properly sized and in suitable condition for application of materials.
- b. Surfaces to which firestop materials will be applied shall be free of dirt, grease, oil, rust, laitance, release agents, water repellents, and any other substances that may affect proper adhesion.
- c. Provide masking and temporary covering to prevent soiling of adjacent surfaces by firestopping materials.
- d. Comply with manufacturer's recommendations for temperature and humidity conditions before, during and after installation of firestopping.
- e. Do not proceed until unsatisfactory conditions have been corrected.

K Coordination

1. Coordinate location and proper selection of cast-in-place Firestop Devices with trade responsible for the work. Ensure device is installed before placement of concrete.
2. Responsible trade to provide adequate spacing of field run pipes to allow for installation of cast-in-place firestop devices without interferences.

L. Installation

1. Regulatory Requirements: Install firestop materials in accordance with UL Fire Resistance Directory.
2. Manufacturer's Instructions: Comply with manufacturer's instructions for installation of through-penetration and construction joint materials.
 - a. Seal all holes or voids made by penetrations to ensure an air and water resistant seal.
 - b. Consult with project manager, and damper manufacturer prior to installation of UL firestop systems that might hamper the performance of fire dampers as it pertains to duct work.
 - c. Protect materials from damage on surfaces subjected to traffic.

M. Field Quality Control

1. Examine sealed penetration areas to ensure proper installation before concealing or enclosing areas.
2. Keep areas of work accessible until inspection by applicable code authorities.
3. Perform under this section patching and repairing of firestopping caused by cutting or penetrating of existing firestop systems already installed by other trades.

N. Adjusting and Cleaning

1. Remove equipment, materials and debris, leaving area in undamaged, clean condition.
2. Clean all surfaces adjacent to sealed holes and joints to be free of excess firestop materials and soiling as work progresses.

**CITY OF MERIDEN BOARD OF EDUCATION
ROGER SHERMAN ELEMENTARY SCHOOL
FIRST FLOOR NEW AIR CONDITIONING SYSTEM
MERIDEN, CONNECTICUT**

3.8 ACCESSIBILITY:

- A. Locate all equipment which must be serviced, operated or maintained in fully accessible positions. Equipment shall include but not be limited to motors, controllers, switchgear, drain points, etc. If required for better accessibility, furnish access doors for this purpose. Access doors shall be selected by the Architect/Engineer to specific area finishes. Minor deviations from drawings may be made to allow for better accessibility, only if approved by the Engineer. Provide fire rated access doors in rated walls, access doors shall be provided in Milcor or equal.
- B. In the event that any equipment is not installed to permit convenient servicing, disassemble, removal of parts, etc. the Contractor shall, at his own expense, make all corrections necessary to accomplish this.

3.9 TAGS, CHARTS AND NAMEPLATES:

- A. Each piece of apparatus installed under these sections shall be properly identified.
- B. All equipment shall be provided with a suitable laminated plastic nameplate fastened with screws or rivets. Small equipment labels may use a pressure sensitive tape.
- C. All nameplates and labels shall identify components by proper nomenclature and numbered according to equipment schedule or as designated.

3.10 PIPING CODE MARKERS:

- A. All service piping which is accessible for maintenance operations, except piping in finished spaces, shall be identified with vinyl plastic color bands and legends at each branch and riser take-off, at each passage through wall, floor and ceiling, adjacent to each valve and on all pipe runs marked each 20'-0" on center.

Vinyl plastic bands shall not be used in plenum ceilings. Use self-Adhesive aluminum pipe markers or pipe stencils in plenum areas.

- B. Pipe markers to conform to A.S.A. Bulletin A-13. Where pipes are too small for legends, brass identification tags 1-1/2" in diameter with depressed 1/2" high black filled letters shall be fastened with chain. Pipe markers and tags as manufactured by the Seton Name Plate Corp., New Haven, Conn., or equal approved in Brady or Kolbi.

3.11 INSTRUCTIONS:

- A. Prepare written instructions frames for the proper maintenance and operation of any special equipment furnished and installed under this Contract.
- B. Personally instruct the Owner's Custodian or official representative in addition to furnishing all manuals, diagrams, etc. in the proper operation and maintenance of all equipment and piping installed under this Contract.
- C. Prepare a portfolio with all tags, operating manuals, parts lists, guarantees, etc. that are packed with all equipment furnished under this Contract and submit same to the Architect.

**CITY OF MERIDEN BOARD OF EDUCATION
ROGER SHERMAN ELEMENTARY SCHOOL
FIRST FLOOR NEW AIR CONDITIONING SYSTEM
MERIDEN, CONNECTICUT**

3.12 EQUIPMENT NOT IN CONTACT AND PREPURCHASED BY OWNER:

- A. The Owner has purchased mechanical equipment listed elsewhere. This Contractor shall be given the purchase order and shall at that time assume full responsibility for delivery, installation and guarantee of said equipment as if he has purchased the equipment.
- B. Furnish all piping, wiring, sheet metal connections and miscellaneous accessories, and make all closing connections to equipment furnished by Owner; include installation of all special traps, control valves and supplies furnished with such equipment. Refer to section in which outlines equipment requirements and all other specifications sections as may be pertinent to comply with intent of this Article.
- C. Unless otherwise detailed on drawings, roughing of proper size and capacity for equipment indicated on Mechanical or Electrical drawings as "Future" or "NIC" shall be provided and installed in such a manner and location that future final connection can be made with a minimum of work and without cutting or patching walls, partitions, ceilings or floors.
- D. Engineers' drawings are, of necessity, schematic for special equipment as exact roughing and requirements may vary with different manufacturers.
- E. Contractor shall obtain approved shop drawings of equipment being furnished for extent of final connections and exact roughing required.

3.13 CLEANING PIPING, CONDUITS AND EQUIPMENT:

- A. Thoroughly clean all piping and equipment of all foreign substances inside and out before being placed in operation.
- B. If any part of a system should be stopped by any foreign matter after being placed in operation, the system shall be disconnected, cleaned and reconnected wherever necessary to locate and remove obstructions. Any work damaged in the course of removing obstructions shall be repaired or replaced when the system is reconnected at no additional cost to the Owner.
- C. During the course of construction, all pipe and electrical conduits shall be capped in an approved manner to insure adequate protection against the entrance of foreign matter.

3.14 CLEANING UP:

- A. After completion of the work, remove all waste, rubbish and other materials left as a result of operations and leave the premises in clean condition.
- B. All fixtures, equipment, etc. installed under the Mechanical and Electrical Sections shall be free of dirt, grease and other foreign material and left in perfectly clean condition and ready to use.

3.15 GUARANTEE:

- A. All parts of the work and all equipment shall be guaranteed for a period of at least 18 months from the date of acceptance of the job by the Owner.

**CITY OF MERIDEN BOARD OF EDUCATION
ROGER SHERMAN ELEMENTARY SCHOOL
FIRST FLOOR NEW AIR CONDITIONING SYSTEM
MERIDEN, CONNECTICUT**

- B. If during that period of general guarantee, any part of the work installed fails, becomes unsatisfactory or does not function properly due to any fault in material or workmanship, whether or not manufactured or job built, each section shall upon notice from the Owner, promptly proceed to repair or replace such faulty material or workmanship without expense to the Owner, including cutting, patching and painting or any other work involved and including repair or restoration of any damaged sections of the premises resulting from such faults.
- C. In the event, that a repetition of any one defect occurs, indicating the probability of further failure, and which can be traced to faulty design, material or workmanship, then repairs or replacement shall not continue to be made but, the fault shall be remedied by a complete replacement of the entire defective unit.
- D. In addition to the general guarantee, obtain and transmit to the Owner any guarantees or warranties from manufacturers of specialties but only as a supplement to the general guarantee which will not be invalidated by same.

3.16 OWNER'S INSTRUCTIONS AND SYSTEM OPERATION:

- A. At the time of the job's acceptance by the Owner, Contractor shall furnish one complete set of reproducible approved, certified drawings to the Owner. In addition, Contractor shall furnish maintenance and operating instructions for all equipment including parts list. These instructions shall be written in layman's language and shall be inserted in vinyl covered three-ring loose leaf binder. This information in binder shall be first sent to the approved by the Architect/Engineer before turning over to the Owner.
- B. Upon completion of all work and of all tests, each Division shall furnish the necessary skilled labor and helpers for operating the system and equipment for a period of one (1) day of eight (8) hours, or as otherwise specified. During this period, instruct the Owner or his representative fully in operation, adjustment and maintenance of all equipment furnished. Give at least forty-eight (48) hours notice to the Owner in advance of this period.

3.17 OWNER'S ACCEPTANCE TEST:

- A. After the various systems are complete as determined by preliminary operating tests, the Contractor shall arrange for the Owner's final acceptance tests.
- B. The Contractor shall have present at each acceptance test, representatives of the several Contractors whose work is directly or indirectly involved, with instruments as necessary in accordance with the design and to include the following.
 - 1. All equipment installed and operating in accordance with manufacturer's instructions and performance guarantee.
 - 2. All systems operating in accordance with specifications.
 - 3. All distribution systems properly adjusted for distribution to equipment as specified.
 - 4. All `as built` drawings, valve charts, etc. as specified in various parts of the specifications installed or ready for delivery to the Owner.
- C. The date of the Owner's acceptance of the equipment shall be the start of the 18 months guarantee period.

**CITY OF MERIDEN BOARD OF EDUCATION
ROGER SHERMAN ELEMENTARY SCHOOL
FIRST FLOOR NEW AIR CONDITIONING SYSTEM
MERIDEN, CONNECTICUT**

3.18 TEST:

- A. Conducting Tests: Conduct all tests called for under the various sections or as required and repair or replace any defects. Perform all tests in the presence of and to the satisfaction of the Engineer and such other parties as may have legal jurisdiction.
- B. Defective Work: The Owner shall have the privilege of stopping any of the work not being properly installed. All such defective work shall be repaired or replaced and the tests shall be repeated.
- C. Repair Damaged Work: Repair all damages resulting from tests and replace damaged materials.

END OF SECTION 20 00 50

**CITY OF MERIDEN BOARD OF EDUCATION
ROGER SHERMAN ELEMENTARY SCHOOL
FIRST FLOOR NEW AIR CONDITIONING SYSTEM
MERIDEN, CONNECTICUT**

SECTION 23 05 48 -VIBRATION AND SEISMIC CONTROLS FOR HVAC PIPING & EQUIPMENT

PART 1 - GENERAL

1.1 RELATED DOCUMENTS:

- A. The General Provisions of the Contract, including General and Supplementary Conditions and Division 1, General Requirements, apply to the work specified in this Section.
- B. The General Requirements in Section 200050 shall also govern the work under this Section.

1.2 SECTION INCLUDES:

- A. Vibration isolation and seismic restraints for all mechanical and electrical system including equipment, piping, conduit and ductwork within the building.
- B. The work of this section includes but is not limited to the following:
 - 1. Vibration isolation elements.
 - 2. Equipment isolation bases.
 - 3. Piping flexible connections.
 - 4. Seismic restraints for isolated and non-isolated mechanical and electrical items.

1.3 REFERENCES:

- A. State of Connecticut Building Code.
- B. SMACNA - Seismic Restraint Manual Guidelines for Mechanical Systems.
- C. Mason Industries, Inc. Seismic Restraint Guidelines

1.4 QUALIFICATIONS:

- A. Qualifications: Only firms having five years experience designing and manufacturing seismic devices shall be capable of work in this specification.

1.5 SUBMITTALS:

- A. Submit under provisions of Section 200050.
- B. The submittal material shall include copies of descriptive data for all products and materials including but not limited to the following:
 - 1. Descriptive Data:
 - a. Catalog cuts and data sheets.
 - b. An itemized list showing the items to be isolated and/or seismically restrained, product type or model number to be used and loading and deflection data.
 - c. Seismic restraint calculations.

**CITY OF MERIDEN BOARD OF EDUCATION
ROGER SHERMAN ELEMENTARY SCHOOL
FIRST FLOOR NEW AIR CONDITIONING SYSTEM
MERIDEN, CONNECTICUT**

- d. (Structural or civil engineer's State of Connecticut professional engineer's seal verifying design and calculations for seismic restraining system used.)
2. Shop Drawings:
- a. Drawings showing equipment base construction for each machine, including dimensions, structural member sizes, and support point locations.
 - b. Drawings showing methods of suspension, support guides for conduit, piping and ductwork.
 - c. Drawings showing methods for isolation of conduits, pipes and ductwork penetrating walls and floor slabs.
 - d. Concrete and steel details for bases including anchor bolt locations.
 - e. Number location of seismic restraints and anchors for each piece of equipment.
 - f. Specific details of restraints including anchor bolts for mounting and maximum loading at each location, for each piece of equipment and/or pipe and duct locations.
- 1.6 GENERAL (MANUFACTURER) RESPONSIBILITIES:
- A. Contractor shall have the following responsibilities:
- 1. Determine vibration isolation and seismic restraint sizes and locations per specifications.
 - 2. Provide and install isolation systems and seismic restraints as scheduled or specified.
 - 3. Guarantee specified isolation system deflection.
 - 4. Provide installation instructions, drawings and field supervision to assure proper installation and performance.
 - 5. Substitution of "Internally Isolated" mechanical equipment in lieu of the specified isolation of this section may be acceptable provided that all specified deflections and stamped seismic calculations are supplied by the equipment manufacturer.
- 1.7 PROJECT RECORD DOCUMENTS:
- A. Submit under provisions of Section 200050.
- B. Record actual locations and installation of vibration isolators and seismic restraints including attachment points.

PART 2 - PRODUCTS

- 2.1 MANUFACTURERS:
- A. Mason Industries Inc. models listed below.
- B. Other approved manufacturers providing equivalent products include:
- 1. Vibration Eliminator Co.
 - 2. Amber/Booth Co.

**CITY OF MERIDEN BOARD OF EDUCATION
ROGER SHERMAN ELEMENTARY SCHOOL
FIRST FLOOR NEW AIR CONDITIONING SYSTEM
MERIDEN, CONNECTICUT**

2.2 SEISMIC RESTRAINT TYPES:

- A. General: Installations shall be designed to safely accept external forces of one-half “G” load in any direction for all rigidly supported equipment without failure and permanent displacement of the equipment. Life safety equipment such as (fire pumps, sprinkler piping and emergency generators) shall be capable of safely accepting external forces up to one “G” load in any direction without permanent displacement of the supported equipment. Seismic restraints shall not short circuit vibration isolation systems or transmit objectionable vibration or noise.
- B. Type I (spring mount): Shall comply with general characteristics of spring isolators having a minimum o.d. to o.h. of .8 to 1 and minimum runout of 50% to solid. Shall incorporate snubbing restraint in all directions. Shall be capable of supporting equipment at a fixed elevation during equipment erection. Cast housings shall be ductile iron or aluminum. System to be field bolted or welded to deck with 1 G acceleration capability. Mason Type SSLFH or as approved.
- C. Type II (snubber): Each corner of side shall incorporate a seismic restraint having a minimum 5/8” thick resilient pad limit stops working in all directions. Restraints shall be made of plate, structural members, or square metal tubing concentric within a welded assembly incorporated resilient pads. Angle bumpers are not acceptable. System to be field bolted or welded to a deck with 1 G acceleration capability. Mason Type Z-1011 and Z-1225.
- D. Type III (cable braces): Metal cable type with approved end fastening devices to equipment and structure.

System to be field bolted to deck or overhead structural members using two sided beam clamps to steel or appropriately designed insert for concrete. All parts of system including cables, clamps, excluding fastenings are to be single vendor furnished to assure seismic compliance. Mason Type SCB.
- E. Type IV (neoprene mount): Double deflection neoprene isolator encased in ductile iron or steel casing minimum .30 static deflection. System to be field bolted or welded to deck with 1 G acceleration capacity. Mason Type BR, RBA.
- F. Type V: Non-isolated equipment to be field bolted or welded (powder shots not acceptable) to resist seismic forces unless under 100 lb. Shear force required. Mason Type SAS, SAB.

2.3 VIBRATION ISOLATION – GENERAL:

- A. Vibration Isolation shall control excessive noise and vibration in the building due to the operation of machinery or equipment, and/or due to interconnected piping, ductwork, or conduit. (The installation of all vibration isolation units, and associated hangers and bases, shall be under the direct supervision of the vibration isolation manufacturer’s representative.)
- B. All vibration isolators shall have either known non-deflected heights or calibration markings so that, after adjustment, when carrying their load, the deflection can be verified.
- C. All isolators shall operate in the linear portion of their load versus deflection curve. Load versus deflection curves shall be furnished by the manufacturer and must be linear over a deflection range of not less than 50% above the design deflection.

**CITY OF MERIDEN BOARD OF EDUCATION
ROGER SHERMAN ELEMENTARY SCHOOL
FIRST FLOOR NEW AIR CONDITIONING SYSTEM
MERIDEN, CONNECTICUT**

- D. The theoretical vertical natural frequency for each support point, bases upon load per isolator and isolator stiffness, shall not differ from the design objectives for the equipment as a whole by more than +/- 10%.
- E. All neoprene mountings shall have a Shore hardness of 30 to 60 +/- 5, after minimum aging of 20 days or corresponding oven aging.

2.4 VIBRATION ISOLATOR TYPES:

A. Type A: Spring isolators:

- 1. Minimum diameter of 0.8 of the loaded operating height.
- 2. Corrosion resistance where exposed to corrosive environment with:
 - a. Springs cadmium plated or electro-galvanized.
 - b. Hardware cadmium plated.
 - c. All other metal parts hot-dip galvanized.
- 3. Reserve deflection (from loaded to solid height) of 50% of rated deflection.
- 4. Minimum ¼” thick neoprene acoustical base pad on underside, unless designated otherwise.
- 5. Designed and installed so that ends of springs remain parallel and all springs installed with adjustment bolts.
- 6. Non-resonant with equipment forcing frequencies or support structure natural frequencies.
- 7. Mason Type SLF.
- 8. When used in conjunction with seismic bracing, seismic restraint Type II shall be installed.

B. Type B: Spring isolators shall be same as Type A, except:

- 1. Provide built-in vertical limit stops with minimum ¼” clearance under normal operation.
- 2. Tapped holes in top plate for bolting to equipment when subject to wind load.
- 3. Capable of supporting equipment at a fixed elevation during equipment erection. Installed and operating heights shall be identical.
- 4. Adjustable and removable spring pack with separate neoprene pad isolation.
- 5. Capable of accepting 1 G of acceleration.
- 6. Mason Type SLR.

C. Type C: Spring hanger rod isolators:

- 1. Spring element seated on a steel washer within a neoprene cup incorporating a rod isolation bushing.
- 2. Steel retainer box encasing the spring and neoprene cut.
- 3. When used in conjunction with seismic bracing, seismic restraint Type III shall be installed.
- 4. Mason Type HS.

**CITY OF MERIDEN BOARD OF EDUCATION
ROGER SHERMAN ELEMENTARY SCHOOL
FIRST FLOOR NEW AIR CONDITIONING SYSTEM
MERIDEN, CONNECTICUT**

- D. Type D: Seismic Restraint, Type IV: Double deflection neoprene isolator encased in ductile iron or steel casing minimum .30 static deflection. System to be field bolted or welded to deck with 1 G acceleration capacity. Mason Type BR, RBA.
- E. Type E: Elastomer hanger rod isolators:
1. Molded unit type neoprene element with projecting bushing lining rod clearance hole.
 2. Neoprene element to be minimum 1-3/4" thick.
 3. Steel retainer box encasing neoprene mounting.
 4. Clearance between mounting hanger rod and neoprene bushing shall be minimum of 1/8".
 5. Minimum static deflection of 0.35".
 6. When used in conjunction with seismic bracing, seismic restraint Type III shall be installed.
 7. Mason Type HD.
- F. Type F: Combination spring/elastomer hanger rod isolators:
1. Spring and neoprene isolator elements in a steel box retainer. Neoprene double deflection type. Single deflection is unacceptable. Spring seated in a neoprene cup with extended rod bushing.
 2. Characteristics of spring and neoprene as described in Type A and Type E isolators.
 3. When used in conjunction with seismic bracing, seismic restraint Type III shall be installed.
 4. Mason Type DNHS.
- G. Type G: Pad type elastomer mountings:
1. 3/4" Minimum thickness.
 2. 50 PSI maximum loading.
 3. Waffled design.
 4. Deflection per pad thickness.
 5. Galvanized steel plate between multiple layers or pad thickness.
 6. Suitable bearing plate to distribute load.
 7. Mason Type Super W.
- H. Type H: Grommet type elastomer bushings:
1. One piece molded bridge bearing neoprene.
 2. Washer / bushing shall surround the anchor bolt.
 3. Flat washer face to avoid metal to metal contact.
 4. Mason Type HG.
- I. Type K: Pipe Anchors: All-directional acoustical pipe anchor consisting of a telescopic arrangement of two sizes of steel tubing separated by a minimum one-half inch thickness of heavy-duty neoprene and duck or neoprene isolation material. Vertical restraints shall be provided by similar material arranged to prevent vertical travel in either direction. Allowable loads on the isolation material travel in either direction. Allowable loads on the isolation

**CITY OF MERIDEN BOARD OF EDUCATION
ROGER SHERMAN ELEMENTARY SCHOOL
FIRST FLOOR NEW AIR CONDITIONING SYSTEM
MERIDEN, CONNECTICUT**

material shall not exceed 500 psi and the design shall be balanced for equal resistance in any direction. Isolation to be bolted or welded depending on structure. Mason Type ADA.

2.5 EQUIPMENT BASES:

A. Integral Structural Steel Base, Type B-1:

1. Reinforced as required to prevent base flexure at start-up and misalignment of drive and driven units. Centrifugal fan bases complete with motor slide rails.
2. Drills for drive and driven unit mounting template.
3. Must be utilized with seismic restraint Type I, II, or IV.
4. Mason Type M, WFB.

B. Concrete Inertia Base, Type B-2:

1. Vibration isolator manufacturer shall furnish rectangular structural concrete forms for floating foundation. Bases for split case pumps shall be large enough to provide support for suction and discharge base ells. The base depth shall be a minimum of 1/10 of the longest span but not less than 6" or greater than 14". Forms shall include minimum concrete reinforcement consisting of 1/2" bars or angles in place in 6" centers running ways and a layer 1 1/2" above the bottom and a top layer of reinforcing steel as above for all bases exceeding 120" in one direction. Isolators shall be set into pocket housings which are an integral part of the base construction and set at the proper height to maintain a 1" clearance below the base. Bases shall be furnished with templates and anchor bolt sleeves as part of this system.
2. Must be utilized with seismic restraint Type I, II or IV.
3. Mason Type K, BMK.

2.6 FLEXIBLE CONNECTORS:

A. Elastomer Type FC-1:

1. Manufactured of Kevlar reinforcement and EPDM, both molded and cured with hydraulic presses.
2. Straight connectors to have two spheres reinforced with a molded-in external ductile iron ring between spheres.
3. Elbows shall be long radius type.
4. Rated 250 psi at 170 degrees F. Dropping in a straight line to 170 psi at 250 degrees F for sizes 1-1/2" to 12" elbows. Elbows shall be rated no less than 90% of straight connections.
5. Sizes 10" to 12" to employ control cables with neoprene end fittings isolation from anchor plates by means of 1/2" bridge bearing neoprene bushings.
6. Minimum safety factor, 4:1 at maximum pressure ratings.
7. Systems bolted to victaulic type couplings or gate, butterfly, or check valves to have a minimum 5/8" flange spacer installed between conductor and coupling on flange.
8. Submittals to include test reports.
9. Mason Type Safeflex SFDEJ.

**CITY OF MERIDEN BOARD OF EDUCATION
ROGER SHERMAN ELEMENTARY SCHOOL
FIRST FLOOR NEW AIR CONDITIONING SYSTEM
MERIDEN, CONNECTICUT**

- B. Flexible Stainless Hose, Type FC-2:
 - 1. Type 321 stainless steel braided flexible metal hose.
 - 2. 2" pipe size and smaller: threaded carbon steel fittings.
 - 3. 1 ½" pipe size and larger: Class 150 carbon steel flanges.
 - 4. Suitable for operating pressure with 4:1 minimum safety factor.
 - 5. Flexible Metal Hose Company type DFC and MFC.

- C. Unbraided Exhaust Hose, Type FC-3:
 - 1. Low pressure stainless steel annularly corrugated.
 - 2. Fitted with flanged ends.
 - 3. Maximum temperature 1,500 degrees F.
 - 4. Mason Type SDL-RF.

PART 3 - EXECUTION

3.1 GENERAL SEISMIC RESTRAINT REQUIREMENTS:

- A. Install seismic restraints in accordance with manufacturers recommendations.
- B. Seismic restraining system Type III: Install taut for non-isolated equipment and slack with ½" cable deflection for isolated systems.
- C. Seismically restrain all piping, conduit and ductwork with Type III or Type V seismic restraint in accordance with guidelines outlined below. Restraints which are to be used in conjunction with vibration isolators shall be Type III.
 - 1. Carbon steel piping shall be braced at maximum 40' intervals and at turns of more than 4'. Lateral bracing at maximum 80' intervals. No-hub piping to be braced at maximum 20' intervals or maximum 40' using ½ G acceleration rated couplings.
 - 2. Ductwork shall be braced at maximum 30' and at every turn and duct run end. Lateral bracing at maximum 60'.
- D. Equipment mounted on housekeeping pads: Pads shall be properly doweled or expansion shielded to deck to meet acceleration criteria. Mason Type HPA.
- E. Seismic Restraints are not required for the following:
 - 1. Piping in mechanical rooms or penthouses less than 1-1/4" O.D, except fire protection and gas piping.
 - 2. Piping in other areas less than 2-1/2" O.D. except fire protection and gas piping.
 - 3. Ducts which have a cross sectional area less than 6 square feet.
 - 4. All piping suspended by individual hanger 12" or less in length from the top of the pipe to the bottom of the support for the hanger, except fire protection piping.
 - 5. Fire protection feed mains and cross mains suspended by individual hangers 6" or less in length from the top of the pipe to the bottom of the support for the hanger.

**CITY OF MERIDEN BOARD OF EDUCATION
ROGER SHERMAN ELEMENTARY SCHOOL
FIRST FLOOR NEW AIR CONDITIONING SYSTEM
MERIDEN, CONNECTICUT**

6. All top supported ducts suspended by hangers 12” or less in length from the top of the duct to the bottom of the support for the hanger.
 7. Electrical conduit less than 1-1/2” I.D.
- F. For overhead supported equipment, over stress of the building structure must not occur. Bracing can occur from:
1. Flanges to structural beams.
 2. Upper or lower truss chords in bar joist construction at panel points.
 3. Cast-in-place inserts or drilled and shielded inserts in concrete structures.
- G. Building seismic and/or expansion joints: Install hinged joints at piping crossing expansion joints or fire walls and anchor the piping either side per the detail provided on the contract drawings. Anchors on each end are to be capable of accepting 1.5 times the operating pressure multiplied by the projected area of the pipe. Contractor shall refer to Contract Documents for fire wall and seismic/expansion joint location.
1. Offset shall be accomplished by the annular motion of a double sphere connector (TYPE FC-1) bolted to each end of an intermediate steel pipe. Bracket each joint with hinged steel connections. Hinge shall have a pin / slot assembly on both sides. The completed assembly shall be Mason Type Safeflex SFDEJ-HE.

3.2 GENERAL VIBRATION ISOLATION REQUIREMENTS:

- A. Install isolators in accordance with manufacturer’s recommendations. Vibration isolators shall not cause any change of position resulting in stresses or misalignment.
- B. Mechanical equipment shall be isolated from the building structure by means of noise and vibration isolators.
- C. Each fan and motor assembly shall be supported on a single structural steel frame (where noted on the isolation and seismic schedule). Flexible duct connections shall be provided at inlet and discharge ducts.
- D. Provide pairs of horizontal limit springs (Thrust restraints) on fans with more than 6.0 inch static pressure, and on hanger supported, horizontally mounted axial fans where indicated
- E. Provide resiliently mounted equipment, piping, and ductwork with seismic snubbers. Each inertia base shall have minimum of four seismic snubbers located close to isolators.

Snub equipment designated for post disaster use to 0.05 inch (1.5 mm) maximum clearance. Other snubbers shall have clearance between 0.15 inch (4 mm) and 0.25 inch (7mm).]
- F. Ductwork connected to rotating equipment shall be supported with Type C or Type F isolators for the first three support points.
- G. Installation of piping vibration isolators:
 1. All piping, except fire protection standpipe systems, is included under this section.

**CITY OF MERIDEN BOARD OF EDUCATION
 ROGER SHERMAN ELEMENTARY SCHOOL
 FIRST FLOOR NEW AIR CONDITIONING SYSTEM
 MERIDEN, CONNECTICUT**

2. Vibration isolators shall be installed on all piping outside the shafts as follows:
 - a. Piping in mechanical rooms.
 - b. Piping where exposed on roof.
 - c. Piping connected to rotating equipment and pressure reducing stations.
3. Horizontal suspended pipe 2" and smaller and all steam piping shall be suspended by Type E isolator with a minimum 3/8" deflection. Water pipe larger than 2" shall be supported by Type C or Type F isolator with minimum 1" whichever is greater.
4. Horizontal pipe floor supported at slab shall be supported via Type A with a minimum static deflection of 1" or same deflection as isolated equipment to which pipe connects, whichever is greater.
5. Vertical riser pipe supports under 2" diameter shall utilize Type G isolation pads.
6. Vertical riser guides, if required, shall avoid direct contact of piping with building.
7. Pipe anchors or guides, where required, shall utilize resilient pipe anchors, Mason Industries Type ADA, or equivalent, to avoid direct contact of piping with building.
8. Isolated piping which requires sway bracing shall utilize two neoprene elements, Type G to accommodate tension and compression forces.
9. Pipe extension and alignment connectors: Provide connectors at riser takeoffs, cooling and heating coils, and elsewhere as required, to accommodate thermal expansion and misalignment.

H. Pipe Isolation Schedule
PIPE SIZE - INCH (MM)

ISOLATED DISTANCE FROM EQUIPMENT

1 (25)	120 diameters (3.0m)
2 (50)	90 diameters (4.5m)
3 (80)	80 diameters (6.0m)
4 (100)	75 diameters (7.5m)
6 (150)	60 diameters (9.0m)
8 (200)	60 diameters (12.0m)
10 (250)	54 diameters (13.5m)
12 (300)	50 diameters (15.0m)
16 (400)	45 diameters (18.0m)
24 (600)	38 diameters (23.0m)

3.3 EQUIPMENT INSTALLATION:

A. Requirements for installation on concrete inertia bases shall be as follows:

1. Minimum operating clearance between concrete inertia and base and housekeeping pad or floor shall be 1".
2. The equipment structural steel or concrete inertia base shall be placed in position and supported temporarily by blocks or shims, as appropriate, prior to the installation of the machine or isolators.

**CITY OF MERIDEN BOARD OF EDUCATION
ROGER SHERMAN ELEMENTARY SCHOOL
FIRST FLOOR NEW AIR CONDITIONING SYSTEM
MERIDEN, CONNECTICUT**

3. The isolators shall be installed without raising the machine and frame assembly.
4. After the entire installation is complete and under full operational load, the isolators shall be adjusted so that the load is transferred from the blocks to the isolators. When all isolators are properly adjusted, the blocks or shims shall be barely free and shall be removed.
5. Install equipment with flexibility in wiring connection.
6. Verify that all installed isolator and mounting systems permit equipment motion in all directions. Adjust or provide additional resilient restraints to flexibly limit start-up equipment lateral motion to ¼”.
7. Prior to start-up, clean out all foreign matter between bases and equipment. Verify that there are no isolation short circuits in the base, isolators, or seismic restraints.

3.4 INSPECTION:

- A. Upon completion of the installation of all vibration isolation and seismic restraints, the manufacturer’s local representative shall visit the project job site, visibly inspect all installations and report, in writing, any and all deficiencies from the specifications. Any additional corrective measures required to put the system in total compliance shall be the responsibility of the installing contractor.

END OF SECTION 23 05 48

**CITY OF MERIDEN BOARD OF EDUCATION
ROGER SHERMAN ELEMENTARY SCHOOL
FIRST FLOOR NEW AIR CONDITIONING SYSTEM
MERIDEN, CONNECTICUT**

SECTION 23 07 00 - HVAC INSULATION

PART 1 - GENERAL

1.1 RELATED DOCUMENTS:

- A. The General Provisions of the Contract, including General and Supplementary Conditions and Division 01, General requirements, apply to the work specified in this Section.
- B. The General Requirements in Section 200050 shall also govern the work under this Section.
- C. Scope of Work: This Section contains details for the insulation of pipe and equipment installed under Division 23.

1.2 SUBMITTALS:

- A. In accordance with Section 200050, the following items shall be submitted for approval.
Refrigerant and Condensate pipe insulation

1.3 MECHANICAL SYSTEMS INSULATION:

- A. Furnish and install all thermal and protective insulation as specified herein for piping and equipment as shown on the drawings.
- B. The following mechanical items shall be insulated:
Refrigerant piping (liquid and suction).
Condensate piping

1.4 SYSTEM PERFORMANCE

- A. Insulation materials furnished and installed hereunder should meet the minimum thickness requirements of ASHRAE 90.1 (2010), "Energy Efficient Design of New Buildings," of the American Society of Heating, Refrigeration, and Air Conditioning Engineers. However, if other factors such as condensation control or personnel protection are to be considered, the selection of the thickness of insulation should satisfy the controlling factor.
- B. Insulation materials furnished and installed hereunder shall comply with NFPA 255 and shall have a maximum flame spread index of 25 and a maximum smoke developed index of 50 when tested in accordance with the following testing standard:

Underwriters' Laboratories, Inc. UL 723

Adhesives used for applying the sealed jackets shall also conform to these same ratings. The use of wheat paste or any other material not meeting these requirements will not be allowed.

**CITY OF MERIDEN BOARD OF EDUCATION
ROGER SHERMAN ELEMENTARY SCHOOL
FIRST FLOOR NEW AIR CONDITIONING SYSTEM
MERIDEN, CONNECTICUT**

1.5 QUALITY ASSURANCE

- A. Insulation materials and accessories furnished and installed hereunder shall, where required, be accompanied by manufacturers' current submittal or data sheets showing compliance with applicable specifications.
- B. Insulation materials and accessories shall be installed in a workmanlike manner by skilled and experienced workers who are regularly engaged in commercial insulation work.
- C. All covering and insulating materials shall be manufactured by Johns Manville, Owens-Corning, Knauf, or Armstrong.

1.6 SEAMS:

- A. On exposed insulation, all longitudinal seams shall be kept at the top and back of the pipe and circumferential joints shall be kept to a minimum. Raw end of insulation shall be concealed by neatly folding the ends of the jackets. Fittings, valve bodies and flanges shall be furnished with the same jacket materials used on adjoining insulation.

1.7 PRIOR TESTING:

- A. Covering shall not be applied until all parts of the work have been tested by the Contractor and reviewed by the Engineer.

1.8 VAPOR BARRIER:

- A. Vapor barrier shall be applied in accordance with the manufacturer's instructions to maintain the integrity of the vapor barrier on cold systems.
- B. An approved vapor retarder mastic compatible with PVC must be applied between pipe insulation and fitting cover, and on fitting cover and throat overlap seam.
- C. For fittings where operating temperature is below 45 deg. For where pipe insulation thickness is greater than 1 ½", two or more layers of Hi-Lo temp insulation inserts shall be installed beneath fitting cover.

1.9 METAL SHIELDS:

- A. Metal shields, 16 gauge galvanized, shall be applied between hangers or supports and the pipe insulation. Shields shall be roll formed to fit the insulation and shall extend up to the center line of the pipe and the length specified for the insert. Insulation shall be rigid type for length of shield to prevent crushing.

1.10 DELIVERY AND STORAGE OF MATERIALS

- A. All of the insulation materials and accessories covered by this specification shall be delivered to the job site and stored in a safe, dry place with appropriate labels and/or other product identification.
- B. The contractor shall use whatever means are necessary to protect the insulation materials and accessories (wick material, sealing tape, etc) before, during, and after installation. No insulation

**CITY OF MERIDEN BOARD OF EDUCATION
 ROGER SHERMAN ELEMENTARY SCHOOL
 FIRST FLOOR NEW AIR CONDITIONING SYSTEM
 MERIDEN, CONNECTICUT**

material shall be installed that has become damaged in any way. The contractor shall also use all means necessary to protect work and materials installed by other trades.

PART 2 - PRODUCTS

2.1 PIPING:

- A. Insulate all new condensate lines with Owens-Corning Fiberglass ASJ with S.S.L. II, pipe insulation with double self-sealing lap having a factory applied jacket. Vapor seal all joints, seams, elbows and fittings. All horizontal and vertical insulated piping located below 8'-0" AFF level and not protected with enclosures shall be protected with Zeston 2000 P.V.C. 30 Mil jacketing. All outdoor, exposed piping shall be protected with aluminum jacket.
- B. For all insulated pipes, including refrigerant piping, exposed to weather apply a 16 mil embossed aluminum jacket with 2" overlap at longitudinal and circumferential joints. Secure in place with 3/4" x .015" aluminum band 18" on centers. All seams shall be sealed weather tight.
- D. Foam insulation:
 - 1. Piping and Fittings. MicroLok plain pipe insulation shall be wired or taped in place over clean, dry pipe with all joints butted firmly together. Vapor retarder shall be Micro-Lok AP-T plus.
 - 2. The insulation shall be finished with metal jacketing with a laminated moisture retarder. Metal jacketing shall be overlapped 2 to 3 inches (51 to 76 mm) and held in place with sheet metal screws or metal bands.
 - 3. Elbows and tees shall be finished with matching metal fitting covers. Other fittings in metal-jacketed systems shall be finished with conventional weather-resistant insulating materials with painted aluminum finish.
- E. Insulate all refrigerant lines with Armacell foam insulation with vinyl protective coating. Acceptable substitutions are by Imcolock or Aeroflex.
- F. Provide minimum insulation thickness in accordance with the following table.

Minimum Pipe Insulation

Piping System Types	Conductivity	Mean Rating temp	Fluid Temp. Range	Runout 2 in +	1 in. and less	1-1/4 to 1 1/2	2 to 4 in.	5 and Larger
	BTUin/hsqftF	F	F	in.	in.	in.	in.	in.
Heating Systems								
Low Temp	.25-.29	125	120-200	0.5	1.0	1.0	2	2
Cooling Systems								
Chilled Water or Refrigerant	.22-.28 .22-.28	100 100	40-60 Below 40	.75 1.0	1.0 1.0	1.0 1.5	1.5 1.5	1.5 1.5

**CITY OF MERIDEN BOARD OF EDUCATION
ROGER SHERMAN ELEMENTARY SCHOOL
FIRST FLOOR NEW AIR CONDITIONING SYSTEM
MERIDEN, CONNECTICUT**

Reinsulate duct and pipes where insulation has been disturbed under this contract and feather to remaining insulation.

2.2 REFRIGERANT INSULATION

- A. Insulation shall be a flexible, closed-cell elastomeric pipe insulation: AP Armaflex, AC Accoflex. Adhesive shall be Armaflex 520, 520 Black or 520 BLV Adhesive. The insulation must conform to ASTM C534 Grade 1, Type I.
Insulation materials shall have a closed cell structure to prevent moisture from wicking which makes it an efficient insulation.
Insulation materials shall be manufactured without the use of CFC's, HFC's or HCFC's. It is also formaldehyde free, low VOCs, fiber free, dust free and resists mold and mildew.
Insulation materials shall have a flame-spread index of less than 25 and a smoke-developed index of less than 50 as tested in accordance with ASTM E 84. In addition, the products, when tested, shall not melt or drip flaming particles, and the flame shall not be progressive.
Insulation materials shall have a maximum thermal conductivity of 0.27 Btu-in./h-ft²-°F at a 75°F mean temperature as tested in accordance with ASTM C 177 or ASTM C 518.
Insulation materials shall have a maximum water vapor transmission of 0.08 perm-inches when tested in accordance with ASTM E 96, Procedure A.
- B. All liquid and suction lines shall be insulated continuously from a point 6" inside the display case to the suction service valve at the compressor.
All low temperature lines (+10°F and below) shall be insulated with a minimum of 1" wall thickness.
All medium and high temperature lines (above +10°F) shall be insulated with a minimum of 3/4" wall thickness.
Heat reclaim lines shall be insulated from the condensing unit to the heat reclaim units with 3/4" thickness.
All refrigerant copper lines must be free of extraneous chemicals such as corrosive cleaners or building materials' dust prior to the installation of the insulation. The insulation must be clean and dry prior to installation.
Refrigerant pipe shall be sealed while slipping on insulation to prevent foreign matter from entering the tube.
- C. Insulation is to be slid onto pipe; longitudinal slitting of the insulation is not allowed except on mitered sections. Insulation shall be pushed onto pipe, not pulled.
Insulation shall be mitered, preadhered and longitudinally slit inside throat to fit over all P-traps, tees and elbows or bends over 90°.
All butt joints and mitered seams shall be adhered with full coverage of adhesive on both surfaces. Insulation shall not be stretched when adhering.
- D. Insulation must be installed in an adequately ventilated area. It may be necessary to increase insulation thickness if adequate ventilation is not present, Do not crowd the insulation, allow for adequate air movement.
At the beginning, at every 12 to 18 feet, and at the ends of piping runs, the insulation shall be adhered directly to the copper using a 2" strip of adhesive. Insulation should not be adhered to the pipe at the extreme low points in any piping run.
Saddles shall be installed under all insulated lines at unistrut clamps, clevis hangers, or locations where insulation may be compressed.
- E. Armafix IPH or NPH insulation pipe hangers can be installed at the compression locations and the seams shall be sealed with Armaflex 520, 520 Black or 520 BLV contact adhesive. To minimize the movement of Armafix, it is recommended that a pair of non-skid pads be adhered to the clamps. In addition, to prevent loosening of the clamps, use of an anti-vibratory fastener, such as a nylon-locking nut, is also recommended.
Wood dowels or blocks, of a thickness equal to the insulation, can be inserted and must be completely sealed into the insulation at the saddle locations. All seams shall be sealed with

**CITY OF MERIDEN BOARD OF EDUCATION
ROGER SHERMAN ELEMENTARY SCHOOL
FIRST FLOOR NEW AIR CONDITIONING SYSTEM
MERIDEN, CONNECTICUT**

Armaflex 520, 520 Black or 520 BLV contact adhesive.

Hangers clamped directly to the pipe shall be insulated over the hanger; insulation shall be fully adhered to the hanger. In addition, hangers with double rods shall be insulated between the rods. All seams of the insulation shall be sealed with adhesive.

All insulation exposed to sunlight or installed outdoors shall be protected with two coats of WB Armaflex Finish or weather resistant coating and aluminum jacket.

2.3 FITTING COVERS:

- A. Fitting covers may be used in lieu of insulating cement and jacket. Provide fitting covers in Zeston - 2000 P.V.C. (20 Mil thickness) by Manville. Provide color coded fitting covers in Zeston 300 Series 30 Mil jacket for fittings located in the Mechanical Rooms and Mechanical Penthousees. Acceptable substitutions are by SpeedLine or Proto.
- B. General - The matching insert (fiberglass) should either be wrapped completely around the fitting or snugly positioned inside the fitting for proper fit. The insert shall cover the full inner surface area of the fitting cover. The fitting cover is then to be applied over the fitting and insert, and the throat secured by either tack fastening, taping, or banding.
- C. Cold Pipe - Fitting systems below ambient temperature must have a continuous vapor barrier, either with pressure sensitive PVC Tape, or an approved adhesive system. When PVC Tape is used, a 2" downward lap is required. On cold lines in severe ambient temperatures, the fiberglass insert shall be the same thickness as the adjacent pipe insulation. All joints shall then be sealed with PVC Tape.

PART 3 – EXECUTION

3.1 SITE INSPECTION

- A. Before starting work under this section, carefully inspect the site and installed work of other trades and verify that such work is complete to the point where installation of materials and accessories under this section can begin.
- B. Verify that all materials and accessories can be installed in accordance with project drawings and specifications and material manufacturer's recommendations.
- C. Verify, by inspecting product labeling, submittal data, and/or certifications which may accompany the shipments, that all materials and accessories to be installed on the project comply with applicable specifications and standards and meet specified thermal and physical properties.

3.2 PREPARATION

- A. Ensure that insulation is clean, dry, and in good mechanical condition and that all factory-applied facings are intact and undamaged. Wet, dirty, or damaged insulation is not acceptable for installation.
- B. Ensure that pressure testing of piping and fittings has been completed prior to installing insulation.

**CITY OF MERIDEN BOARD OF EDUCATION
ROGER SHERMAN ELEMENTARY SCHOOL
FIRST FLOOR NEW AIR CONDITIONING SYSTEM
MERIDEN, CONNECTICUT**

3.3 INSTALLATION

A. General

1. Install all insulation materials and accessories in accordance with manufacturer's published instructions and recognized industry practices to ensure that it will serve its intended purpose.
2. Install insulation on piping subsequent to painting, and acceptance tests.
3. Install insulation materials with smooth and even surfaces. Insulate each continuous run of piping with full-length units of insulation, with single cut piece to complete run. Do not use cut pieces or scraps abutting each other. Butt insulation joints firmly to ensure complete, tight fit over all piping surfaces.

B. Fittings

1. Wrap valves, fittings, and similar items in each piping system with wicking material to ensure a continuous path (100% coverage) for the removal of condensation.
2. Seal all fitting joints with contractor supplied VaporWick Sealing Tape or approved vapor retarder mastic compound.

C. Penetrations

Extend piping and duct insulation without interruption through walls, floors and similar piping or duct penetrations.

3.4 FIELD QUALITY ASSURANCE

- A. Upon completion of all insulation work covered by this specification, visually inspect the work and verify that it has been correctly installed. This may be done while work is in progress, to assure compliance with requirements herein to cover and protect insulation materials during installation.
- B. Replace any ceiling damage caused by condensation due to improper covering and sealing during the guarantee period of this job.

3.5 PROTECTION

- A. Replace damaged, removed or disturbed insulation with appropriate fiberglass insulation.
- B. The insulation contractor shall advise the general and/or the mechanical contractor as to requirements for protection of the insulation work during the remainder of the construction period, to avoid damage and deterioration of the finished insulation work.

3.6 SAFETY PRECAUTIONS

- A. Insulation contractor's employees shall be properly protected during installation of all insulation. Protection shall include proper attire when handling and applying insulation materials, and shall include (but not be limited to) disposable dust respirators, gloves, hard hats, and eye protection.

**CITY OF MERIDEN BOARD OF EDUCATION
ROGER SHERMAN ELEMENTARY SCHOOL
FIRST FLOOR NEW AIR CONDITIONING SYSTEM
MERIDEN, CONNECTICUT**

- B. The insulation contractor shall conduct all job site operations in compliance with applicable provisions of the Occupational Safety and Health Act, as well as with all state and/or local safety and health codes and regulations that may apply to the work.

END OF SECTION 23 07 00

**CITY OF MERIDEN BOARD OF EDUCATION
ROGER SHERMAN ELEMENTARY SCHOOL
FIRST FLOOR NEW AIR CONDITIONING SYSTEM
MERIDEN, CONNECTICUT**

SECTION 23 21 13- PIPING

PART 1 - GENERAL

1.1 RELATED DOCUMENTS:

- A. The General Provisions of the Contract, including General and Supplementary Conditions and General Requirements, apply to the work specified in this Section.
- B. The General Requirements in Section 200050 shall also govern the work under this Section.
- C. Examine all drawings and data and coordinate the work of this Section with all related and adjoining work.

1.2 SCOPE OF WORK:

- A. This Contract includes all labor, material, equipment, tests and appliances required to furnish and install all HVAC as shown on drawings, implied and herein specified.
- B. The present location of the building will be as shown on drawings. Visit the site and examine the Architectural and other Mechanical trades showing all details of construction before submitting proposal.
- C. Connect all equipment with piping and controls and leave ready to operate. Check all Mechanical and Electrical drawings and coordinate all work accordingly.
- D. Provide seismic restraints, vibration isolators and flexible connections in accordance with Section 230548. Provide flexible connections at all locations where pipes cross building seismic or expansion joints. Verify in the field.
- E. Drawings are diagrammatic and indicate the general arrangement of piping and do not show all minor details and fittings. Such items shall be included, as well as reasonable modification, in the layout as directed to prevent conflict with other trades.

1.3 SUBMITTALS:

- A. In accordance with Section 200050, the following items shall be submitted for review.

Pipe and fittings

1.4 ACCESS DOORS AND PANELS:

- A. Furnish and set access doors and frame for all valves and controls which are concealed in furred spaces. All access doors shall be furnished in Milcor, of flush type with frame and all doors shall be hinged with flush catches. Provide non-ferrous in all wet areas. Access doors shall be fire rated consistent with wall or ceiling in which they are installed.

**CITY OF MERIDEN BOARD OF EDUCATION
 ROGER SHERMAN ELEMENTARY SCHOOL
 FIRST FLOOR NEW AIR CONDITIONING SYSTEM
 MERIDEN, CONNECTICUT**

- B. Where access is required to valves, etc., that occur above lay-in ceilings, these access doors can be omitted, provided suitable plastic markers identifying exact location of valves etc., on lay-in ceilings are applied directly below valve grouping and identified by a number, this number to be used as a marking on valve chart. Markers shall be applied to the ceiling grid, not the ceiling tile.

PART 2 -PRODUCTS

2.1 PIPE AND FITTINGS:

- A. Copper Tubing:
 - 1. Type "L", ASTM Specifications B88, shall be used for water lines.
 - 2. Fittings shall be wrought copper or cast brass solder- joint pressure rated type.
 - 3. Type "K" shall be used for underground piping with flared fittings.

2.2 PIPE HANGERS:

- A. Securely hang and anchor pipe as shown and required with proper provision for expansion, contraction and elimination of undue stress and strain on piping.
- B. Provide a pipe hanger within two (2) feet of each elbow, tee, wye, valve, strainer and similar device.
- C. Secure and support runs at base and at sufficiently close intervals to hold pipe at alignment and to carry safely the weight of piping and contents without undue stress thereon.
- D. Except as indicated to the contrary, secure and support all horizontal piping as follows and required to prevent sagging, undue pipe movement and preserve proper alignment in each run.

<u>Piping</u>	<u>Sizes</u>	<u>Maximum Interval</u>
Copper Tubing	1 1/4" & smaller	Five (5) feet
Copper Tubing	1 1/2" & larger	Eight (8) feet

- E. Hangers up to and including 2" shall be the adjustable band type equal to Empire. Figure 310 for iron pipe and Fig. 310CT for copper tubing.
- F. Hangers for piping 2-1/2" and up shall be the clevis type, equal to Empire. Figure 11 for iron pipe and Figure 110CT for copper tubing.
- G. Hangers shall be suspended from one of the following devices:
 - 1. "C" clamps.
 - 2. Trapeze hanger assemblies consisting of back-to-back horizontal steel channels with end-type rod hangers.
 - 3. Expansion shield embedded into concrete or masonry.
- H. On refrigerant systems, provide over-sized hangers.
- I. Refer to Section 230548 for Seismic Restraints.

**CITY OF MERIDEN BOARD OF EDUCATION
ROGER SHERMAN ELEMENTARY SCHOOL
FIRST FLOOR NEW AIR CONDITIONING SYSTEM
MERIDEN, CONNECTICUT**

2.3 FLOOR AND CEILING PLATES:

- A. Furnish and install satin chrome plated pressed metal floor and ceiling plates on all exposed pipes passing through floors, walls, ceilings, and partitions throughout.

2.4 REAMING OF PIPES:

- A. All pipes to be carefully reamed after cutting and threading.

2.5 PIPE ANCHORS:

- A. Furnish and install all steel clamps around mains not less than 1/4" thick and welded to pipe and necessary angle braces to substantial construction to meet job conditions. Anchored mains shall be properly guided.
- B. Vertical risers, if any, shall be anchored by similar clamps secured to floor, concealed in wall construction.

2.6 HANGERS AND SLEEVES:

- A. All horizontal piping shall be supported in a good, firm and substantial manner. No chains, horizontal pieces of pipe or hangers formed by means of perforated steel bands, pipe rings and hooks will be permitted. Provide cast iron ceiling plates for all hangers in finished basement ceilings. All hangers shall be oversized
- B. Furnish and place "Hole-Outs" plastic preformed knockout sleeves for all pipes passing through concrete or tile floors or partitions. All pipes passing through toilet room and mechanical room floors shall be provided with grouted, split Schedule 80 steel pipe sleeves, packed with hair felt and Portland cement to allow for flushing of floors without leakage. All pipes and conduits passing through floors, walls or partitions shall be provided with sleeves sized to give a minimum of 1/2" clearance between sleeve and the outside diameter of the pipe, conduit or insulation, enclosing the pipe or conduit.
- C. Sleeves through concrete floors or interior masonry walls shall be Schedule 40 steel pipe, set flush with finished wall or ceiling surfaces, but extending 2 inches above finished floors or shall be in accordance with details on drawings. In all mechanical equipment rooms or penthouses, sleeves shall extend 6 inches above finished floor.
- D. All outside piping passing through exterior walls, foundation walls and floors shall be furnished with flanged C.I. wall sleeves in Zurn, J.R. Smith or Josam. Furnish with flashing clamp where sleeve passes through waterproof membrane.

**CITY OF MERIDEN BOARD OF EDUCATION
ROGER SHERMAN ELEMENTARY SCHOOL
FIRST FLOOR NEW AIR CONDITIONING SYSTEM
MERIDEN, CONNECTICUT**

2.7 REFRIGERANT PIPING:

- A. All refrigerant piping shall be installed in compliance with all state and local code requirements.
- B. Contractor shall field verify piping length and layout with the equipment manufacturer prior to start of any work. Contractor shall submit a shop drawing showing refrigeration pipe layout, lengths and pipe sizes prior to start of installing any refrigeration piping.
- C. Refrigerant piping shall be copper tube ASTM B 280, Type ACR, hard-drawn straight lengths or soft-annealed coil, seamless copper tubing. Tubing shall be factory cleaned, ready for use and installation, and have ends capped to protect cleanliness of pipe interior.
- D. Fittings shall be Wrought-Copper fittings ANSI B16.22, streamline pattern.
- E. Tubing shall be joined using brazing filler material such as phoscopper or silver alloy. Comply with the procedures contained in the AWS "Brazing Manual". Contractor shall take all appropriate precautions when conducting brazing work to protect the building and people from fumes, fire and smoke. Fill pipe with inert gas such as dry nitrogen to prevent formation of scale while brazing.
- F. Contractor shall coordinate and provide all refrigeration piping specialties as required by the refrigeration equipment manufacturer to ensure a complete and functioning refrigeration system. Refrigeration specialties shall be UL approved, listed and shall conform to ASI 760.
- G. Install refrigerant piping in accordance with ASHRAE standard 15. Install piping in as short and direct manner as possible to minimize pressure drop and refrigerant volume. Install using the fewest number of joints and fittings as possible.
- H. Arrange piping to allow for inspection, leak testing, and servicing of the fittings and adjacent equipment. Allow for adequate service clearances of piping and equipment.
- I. Provide insulation for refrigeration piping and condensate drain piping as recommended by the equipment manufacturer. If the manufacturer does not have any insulating requirements or recommendations then the contractor shall at minimum insulate the suction line from the evaporator to the condensing unit (compressor inlet) and the condensate drain line.

Do not install insulation until all refrigerant piping has been tested and proven to be free from leaks. Insulation shall be UV resistant and shall comply with NFPA requirements for fire and smoke developed rating for foam and insulating materials.

- J. All penetrations shall be sleeved and shall be sealed. Provide weather tight seal for exterior pipe penetrations and firestopping for interior penetrations. Materials shall be of an approved type for the application.
- K. If necessary to remove refrigerant from the system the contractor is expected to adhere to all regulations and procedures governing reclaiming of the refrigerant. Under no circumstances may refrigerant be purged or released to the atmosphere.
- L. The contractor shall test all refrigerant piping and completely evacuate the refrigerant system using a vacuum pump. Contractor shall create a vacuum within the system corresponding to a temperature of 35 deg F on a vacuum dehydration indicator. Contractor shall valve off pump and inspect that system vacuum is maintained for a minimum of five (5) hours. Contractor shall then

**CITY OF MERIDEN BOARD OF EDUCATION
ROGER SHERMAN ELEMENTARY SCHOOL
FIRST FLOOR NEW AIR CONDITIONING SYSTEM
MERIDEN, CONNECTICUT**

break vacuum using the approved refrigerant for the equipment connected to the piping system. Allow pressure to build gradually to a minimum holding charge pressure of 5 psi.

- M. Contractor shall measure and fill the refrigerant system with the type and quantity of refrigerant specified by the refrigeration equipment manufacturer. Contractor shall also take pipe volume and other additional line volume into account when charging the system. Contractor shall verify that sufficient operating charge is provided and leave system in full operating order.

PART 3 -EXECUTION

3.1 INSTALLATION:

- A. Furnish and install the refrigerant and condensate piping as shown on plans.
- B. Check electrical drawings to make sure that this piping will not conflict with such work.
- C. All piping work shall be installed with proper provision to allow for expansion and contraction of lines so as to prevent any undue strains on pipe and fittings, any trapping of lines or lifting or dislocating of any appliances. Rectify without cost to the Owner any expenses of cutting and repairing of the building structure incident to making such alterations.
- D. Install the work to conform to space conditions and the work of other trades. The drawings indicate generally the runs and sizes of piping and, although the size must not be decreased, nor the drawings deviated from, except as unforeseen space conditions may require, the right is reversed to make minor changes in the arrangement of the work to meet conditions arising during construction.
- E. Provide expansion fittings at all locations where pipes cross expansion or seismic joints. Coordinate with Architectural drawings for locations.

3.2 MISCELLANEOUS PIPING:

- A. Furnish and install copper drain lines from cooling coil drain pans and extend to outside whether or not same is shown.

3.3 TESTING:

- A. All flow piping shall be tested and made tight.
- B. After the system is thoroughly cleaned, it shall be put into operation by this Contractor. All parts of the system shall be thoroughly tested and this Contractor shall carefully instruct the Owner's authorized representative as to the proper operation and care of the entire system.
- C. After the systems are thoroughly cleaned, they shall be put into operation by the Heating Contractor. All parts of the system shall be thoroughly tested and this Contractor shall carefully instruct the Owner's authorized representatives as to the proper operation and care of the entire system.

END OF SECTION 23 21 13

**CITY OF MERIDEN BOARD OF EDUCATION
ROGER SHERMAN ELEMENTARY SCHOOL
FIRST FLOOR NEW AIR CONDITIONING SYSTEM
MERIDEN, CONNECTICUT**

SECTION 23 81 19- VARIABLE REFRIGERANT VOLUME DIRECT EXPANSION SYSTEMS

PART 1 - GENERAL

1.1 RELATED DOCUMENTS:

- A. The General Provisions of the Contract, including General and Supplementary Conditions and General Requirements, apply to the work specified in this Section.
- B. The General Requirements in Section 200050 shall also govern the work under this Section.
- C. Examine all drawings and data and coordinate the work of this Section with all related and adjoining work.

1.2 SCOPE OF WORK:

- A. This Contract includes all labor, material, equipment, tests and appliances required to furnish and install all HVAC as shown on drawings, implied and herein specified.
- B. The present location of the building will be as shown on drawings. Visit the site and examine the Architectural and other Mechanical trades showing all details of construction before submitting proposal.
- C. Connect all equipment with piping and controls and leave ready to operate. Check all Mechanical and Electrical drawings and coordinate all work accordingly.
- D. Provide seismic restraints, vibration isolators and flexible connections in accordance with Section 230548. Provide flexible connections at all locations where pipes cross building seismic or expansion joints. Verify in the field.
- E. Drawings are diagrammatic and indicate the general arrangement of piping and do not show all minor details and fittings. Such items shall be included, as well as reasonable modification, in the layout as directed to prevent conflict with other trades.

1.3 SUBMITTALS:

- A. In accordance with Section 200050, the following items shall be submitted for review.

VRF System

1.5 SYSTEM DESCRIPTION

- 1. The variable capacity, heat pump air conditioning system shall be a DAIKIN Variable Refrigerant Volume (VRV) System.
- 2. The system shall consist of outdoor units, REFnet joints and indoor units with DDC (Direct Digital Controls). Each indoor unit or group of indoor units shall be independently controlled.

**CITY OF MERIDEN BOARD OF EDUCATION
ROGER SHERMAN ELEMENTARY SCHOOL
FIRST FLOOR NEW AIR CONDITIONING SYSTEM
MERIDEN, CONNECTICUT**

3. The VRV system selected shall be of the "heat pump" type to provide non-simultaneous heating or cooling via a 2-pipe refrigeration pipe design to the indoor units.
4. All refrigerant lines shall be insulated according to the manufacturer's recommendations. Piping shall be furnished by the mechanical contractor.

1.6 QUALITY ASSURANCE

1. The units shall be listed by Electrical Laboratories (ETL) and bear the ETL label.
2. All wiring shall be in accordance with the National Electrical Code (N.E.C.).
3. The system will be produced in an ISO 9001 and ISO 14001 facility, which are standards set by the International Standard Organization (ISO). The system shall be factory tested for safety and function.
4. The system shall use R-410A refrigerant only. A full charge of R-410A for the condensing unit only shall be provided in the condensing unit. All extra refrigerant shall be furnished by the mechanical contractor.

1.7 DELIVERY, STORAGE AND HANDLING

1. Unit shall be stored and handled according to the manufacturer's recommendations.

1.8 INSTALLATION

1. The VRV system shall be installed by a manufacturer authorized installer with training specific to the equipment being installed. The mandatory contractor service and install training should be performed by the manufacturer or the local representative. Untrained contractors who wish to bid this project may contact the local Daikin representative (Swan Associates – Newington, CT – 860-666-6923) to arrange training prior to installation.

1.9 STARTUP

1. The DAIKIN VRV system startup will be supported locally by certified Daikin VRV technicians. All wiring, piping, evacuation and an initial charge of R-410A shall be completed by the mechanical contractor prior to having a DAIKIN VRV certified technician called out to witness and assist with startup. The certified technician shall provide technical support and assist with startup; pressure testing, leak testing, evacuation and refrigerant charging shall be by the mechanical contractor. Additional refrigerant will be required and shall be furnished by the mechanical contractor.

**CITY OF MERIDEN BOARD OF EDUCATION
ROGER SHERMAN ELEMENTARY SCHOOL
FIRST FLOOR NEW AIR CONDITIONING SYSTEM
MERIDEN, CONNECTICUT**

1.10 WARRANTY

1. Furnish ten year manufacturer's warranty for all parts and compressors for VRV outdoor condensing units and indoor units. Controls shall be warranted for a period of 18 months from substantial completion. Owner/contractor must retain strict record of all maintenance and follow the factory recommended instructions

PART 2 -PRODUCTS

2.1 OUTDOOR AIR COOLED VRV CONDENSING UNIT:

1. General: The outdoor unit shall be used with compatible indoor components. The outdoor units shall be equipped with multiple circuit boards that interface to the D-III NET controls system and shall perform all functions necessary for operation. The outdoor unit shall have a powder coated finish. The outdoor unit shall be completely factory assembled, piped and wired. Each unit shall be run tested at the factory.
 - a. The refrigeration circuit of the condensing unit shall consist of Daikin inverter scroll compressors, motors, fans, condenser coil, electronic expansion valves, solenoid valves, 4-way valve, distribution headers, capillaries, filters, shut off valves, oil separators, service ports, liquid receiver and suction accumulator.
 - b. To ensure the liquid refrigerant does not flash when supplying to the various indoor units, the circuit shall be provided with a sub-cooling feature.
 - c. The sum of connected capacity of all indoor air handlers shall range from 50% to 200% of outdoor rated capacity.
 - d. The condensing unit shall be factory assembled in the USA and pre-wired with all necessary electronic and refrigerant controls.
 - e. Low sound levels - Each system shall use indoor and condensing units with quiet operation as low as 27 dB(A). The sound pressure level standard shall be that value as listed in the Daikin engineering manual for the specified models at 3 feet from the front of the unit. The outdoor unit shall be capable of operating automatically at further reduced noise during night time.
 - f. Refrigerant lines shall be insulated.
 - g. The outdoor unit shall have an accumulator with refrigerant level sensors and controls.
 - h. The outdoor unit shall have a high pressure safety switch, over-current protection and DC bus protection.
 - i. The system shall be capable of refrigerant piping up to 540 actual feet or 620 equivalent feet from the outdoor unit to the furthest indoor unit, a total combined liquid line length of 3,280 feet of piping between the condensing and indoor units with 295 feet maximum vertical difference, without any oil traps. Systems shall be capable of up to 295ft (90m) from the first REFNET™ / branch point.
 - j. REFnet™ piping joints and headers shall be used to ensure proper refrigerant balance and flow for optimum system capacity and performance. T style joints shall not be acceptable.
 - k. The condensing unit shall be capable of heating operation at negative 4°F wet bulb ambient temperature without additional low ambient controls or an auxiliary heat source.
 - l. The outdoor unit shall have a high efficiency oil separator plus additional logic controls to ensure adequate oil volume in the compressor is maintained.
 - m. Defrost Heating – Multiple condenser VRV systems shall maintain continuous heating during defrost operation. Reverse cycle (cooling mode) defrost operation shall not be permitted due to the potential reduction in space temperature. It is important to the comfort of the design that the

**CITY OF MERIDEN BOARD OF EDUCATION
ROGER SHERMAN ELEMENTARY SCHOOL
FIRST FLOOR NEW AIR CONDITIONING SYSTEM
MERIDEN, CONNECTICUT**

system shall continue to provide heat to the indoor units in heating operation while in the defrost mode.

- n. Oil Return Heating – VRV systems shall maintain continuous heating during oil return operation. Reverse cycle (cooling mode) oil return during heating operation shall not be permitted due to the potential reduction in space temperature.
 - o. Stable Operation – System shall provide stable inverter operation at varied ambient conditions.
 - p. No Drain Pan Heater – System shall be capable of heating operation without the need for a drain pan heater.
 - a) If alternate manufacturer is chosen, an additional drain pan heater shall be provided by the manufacturer and any cost increases due to electrical shall be the responsibility of the mechanical contractor.
 - q. Advanced Zoning - A single system shall provide for up to 64 zones.
 - r. VFD Inverter Control and Variable Refrigerant Temperature - Each condensing unit shall use high efficiency, variable speed all “inverter” based flash vapor injection compressor(s) coupled with inverter fan motors to optimize part load performance. The system capacity and refrigerant temperatures shall be modulated automatically to set suction and condensing pressures while varying the refrigerant volume for the needs of the cooling or heating loads. The control will be automatic and customizable depending on load and weather conditions.
 - a) Indoor shall use PID to control superheat to deliver a comfortable room temperature condition and optimize efficiency.
 - s. The following safety devices shall be included on the condensing unit; high pressure sensor and switch, low pressure sensor, control circuit fuses, crankcase heaters, fusible plug, overload relay, inverter overload protector, thermal protectors for compressor and fan motors, over current protection for the inverter and anti-recycling timers.
 - t. Scheduled heating and cooling capacities shall be met at a minimum and resizing may be needed by other manufacturers to meet this requirement.
 - u. Space saving – Each system shall have a condensing unit module footprint no larger than 66-11/16” x 48-7/8” x 30-3/16” (1694mm x 1242mm x 767mm).
 - v. Each condensing unit shall include a multi-functional digital display that can provide system operation status such as operating refrigerant temperatures, pressures, outdoor electronic expansion valve opening and compressor operation time.
 - w. Each condensing unit shall include a service window that can provide easy access to system field settings and operation status without completely removing the condensing unit panel.
 - x. Advanced diagnostics – Systems shall include a self-diagnostic, auto-check function to detect a malfunction and display the type and location.
 - y. The system will automatically restart operation after a power failure and will not cause any settings to be lost, thus eliminating the need for reprogramming.
 - z. Each system shall be able to enlarge from single to dual module or dual to triple module without the need for installed main pipe size changes. The manufacturer shall provide predefined pipe sizes and design rules ensuring reliable system operation and offering design flexibility in phased installation applications.
2. Unit Cabinet:
- a. The outdoor unit shall be completely weatherproof and corrosion resistant. The unit shall be constructed from rust-proofed mild steel panels coated with a baked enamel finish.
 - b. The unit shall be elevated on rails or stands according to the manufacturer’s recommendation. Failure to do so shall void the manufacturer’s warranties. Rails/stands are not provided by the manufacturer.

**CITY OF MERIDEN BOARD OF EDUCATION
ROGER SHERMAN ELEMENTARY SCHOOL
FIRST FLOOR NEW AIR CONDITIONING SYSTEM
MERIDEN, CONNECTICUT**

3. Fan:
 - a. The unit shall be furnished with one or more direct drive fan motor(s) that have multiple speed operation via a DC (digitally commutating) inverter.
 - b. The fan motor shall have inherent protection, have permanently lubricated bearings, and be completely variable speed.
 - c. The fan motor shall be mounted for quiet operation.
 - d. The fan shall be provided with a raised guard to prevent contact with moving parts.
 - e. The outdoor unit shall have vertical discharge airflow.
 - f. The fan motor shall be factory set as standard at 0.12 in. WG, but contain a field setting switch to a maximum 0.32 in. WG pressure.
 - g. Night setback control of the fan motor for low noise operation by way of automatically limiting the maximum speed shall be a standard feature. Operation sound level shall be selectable from 3 steps
 - h. The condensing unit shall have configurable settings for intermittent fan operation to help minimize snow accumulation on fan blades when the system is off.

4. Coil
 - a. The condenser coil shall be manufactured from copper tubes expanded into aluminum fins to form a mechanical bond.
 - b. The heat exchanger coil shall be of a waffle louver fin and rifled bore tube design to ensure high efficiency performance.
 - c. The heat exchanger on the condensing units shall be manufactured from Hi-X seamless copper tube with N-shape internal grooves mechanically bonded on to aluminum fins to an e-Pass Design.
 - d. The outdoor coil shall have three-circuit heat exchanger design eliminating the need for a drain pan heater The lower part of the coil shall be used for inverter cooling and be on or off during heating operation enhancing the defrost operation.
 - e. The fins shall be coated with an anti-corrosion hydrophilic blue coating as standard from factory with a salt spray test rating of 1000hr per ASTM test standards.
 - f. The condensing unit shall be factory equipped with condenser coil guards on all sides.

5. Compressor:
 - a. The Daikin inverter Flash Vapor injection scroll compressors shall be variable speed (PVM inverter) controlled which is capable of changing the speed to follow the variations in total cooling and heating load as determined by the suction gas pressure as measured in the condensing unit.
 - a) In addition, samplings of evaporator and condenser temperatures shall be made so that the high/low pressures detected are read every 20 seconds and calculated. With each reading, the compressor capacity (INV frequency) shall be controlled to eliminate deviation from target value.
 - b) Non –inverter-driven compressors, which may cause starting motor current to exceed the nominal motor current (RLA) and require larger wire sizing, shall not be allowed.
 - b. The inverter driven compressors in the condensing unit shall be of highly efficient reluctance DC (digitally commutating), hermetically sealed scroll “K-type”.
 - c. Neodymium magnets shall be adopted in the rotor construction to yield a higher torque and efficiency in the compressor instead of the normal ferrite magnet type.
 - a) At complete stop of the compressor, the neodymium magnets will position the rotor into the optimum position for a low torque start.
 - d. The capacity control range shall be as low as 3% to 100%.
 - e. The compressor’s motor shall have a cooling system using discharge gas, to avoid sudden changes in temperature resulting in significant stresses on winding and bearings.

**CITY OF MERIDEN BOARD OF EDUCATION
ROGER SHERMAN ELEMENTARY SCHOOL
FIRST FLOOR NEW AIR CONDITIONING SYSTEM
MERIDEN, CONNECTICUT**

- f. Each compressor shall be equipped with a crankcase heater, high pressure safety switch, and internal thermal overload protector.
- g. Oil separators shall be standard with the equipment together with an intelligent oil management system.
- h. The compressor shall be mounted on vibration dampening rubber grommets to minimize the transmission of vibration, eliminating the standard need for external spring isolation.
- i. In the event of compressor failure, the remaining compressors, if applicable, shall continue to operate and provide heating or cooling as required at a proportionally reduced capacity. The microprocessor and associated controls shall be manually activated to specifically address this condition for single module and manifold systems.
- j. In the case of multiple condenser modules, combined operation hours of the compressors shall be balanced by means of the Duty Cycling Function, ensuring sequential starting of each module at each start/stop cycle, completion of oil return, completion of defrost or every 8 hours. When connected to a central control system sequential start is activated for all system on each DIII network.

2.2 4-WAY CEILING CASSETTE (FXUQ):

- 1. General:
 - a. The unit shall be a ceiling suspended cassette indoor fan coil design that mounts onto the ceiling. The cassette shall be a four-way air distribution type, fresh white, impact resistant with a washable panel. The supply air is distributed via motorized louvers which can be horizontally and vertically adjusted from 0° to 60°. Return air shall be through the concentric panel, which includes a factory provided filter. Computerized PID control shall be used to control superheat to deliver a comfortable room temperature condition. The unit shall be equipped with a programmed drying mechanism that dehumidifies while inhibiting changes in room temperature. The unit shall support individual control using D-III NET DDC controllers.
- 2. Indoor Unit:
 - a. The indoor unit shall be factory assembled, wired and run tested. Contained within the unit shall be all factory wiring, piping, electronic modulating linear expansion device, control circuit board and fan motor. The unit shall have a self-diagnostic function, 3-minute time delay mechanism, and an auto restart function. Indoor unit and refrigerant pipes shall be charged with dehydrated air before shipment from the factory. The unit shall contain a factory installed condensate drain pan and condensate drain pump with float switch.
 - b. The 4-way supply air flow can be field modified to 3-way and 2-way airflow to accommodate various installation configurations including corner installations.
 - c. Independent Control - Each indoor unit shall use a dedicated electronic expansion valve for independent control.
 - d. The indoor units shall be equipped with a return air thermistor.
 - e. All electrical components are reached through the decoration panel, which reduces the required side service access.
 - f. The indoor units sound pressure shall range from 36 dB(A) to 40 dB(A) at low speed measured at 5 feet below the unit.
- 3. Unit Cabinet:
 - a. The cabinet shall be space saving and shall be located into the ceiling.
 - b. Three auto-swing positions shall be available to choose, which include standard, draft prevention and ceiling stain prevention.
 - c. The airflow of the unit shall have the ability to shut down outlets with multiple patterns allowing for simpler installation in irregular spaces.

**CITY OF MERIDEN BOARD OF EDUCATION
ROGER SHERMAN ELEMENTARY SCHOOL
FIRST FLOOR NEW AIR CONDITIONING SYSTEM
MERIDEN, CONNECTICUT**

- d. The cabinet shall be constructed with sound absorbing foamed polystyrene and polyethylene insulation.
4. Fan:
 - a. The fan shall be direct-drive turbo fan type with statically and dynamically balanced impeller with three fan speeds available.
 - b. The fan motor shall operate on 208/230 volts, 1 phase, 60 hertz with a motor output range from 0.06 to 0.14 HP.
 - c. The airflow rate shall be available in three settings.
 - d. The fan motor shall be thermally protected.
5. Filter:
 - a. Return air shall be through the concentric panel, which includes a washable long-life filter with mildew proof resin and antibacterial treatment.
6. Coil:
 - a. Coils shall be of the direct expansion type constructed from copper tubes expanded into aluminum fins to form a mechanical bond.
 - b. The coil shall be of a waffle louver fin and high heat exchange, rifled bore tube design to ensure highly efficient performance.
 - c. The coil shall be a 3-row cross fin copper evaporator coil with 21 FPI design completely factory tested.
 - d. The refrigerant connections shall be flare connections and the condensate will be 1 inch outside diameter PVC.
 - e. A factory mounted condensate pan with an antibacterial treatment shall be provided under the coil.
 - f. A factory mounted condensate pump with a 23-5/8" lift shall be located below the coil in the condensate pan with a built in safety alarm.
 - g. A thermistor will be located on the liquid and gas line.

2.3 ELECTRICAL:

- A. The outdoor unit electrical power shall be 208/230 volts, 3 phase, 60 hertz.
- B. A separate power supply will be required of 208/230 volts, 1 phase, 60 hertz for the indoor units. The voltage range will be 253 volts maximum and 187 volts minimum.
- C. The control circuit between the controls, indoor units, BS Boxes and the outdoor units shall be completed using a 18AWG, 2-wire, stranded, non-shielded cable to provide total integration of the system.
 1. The electrical voltage from each circuit board to the controls shall be 16 volts DC. The voltage may fluctuate up or down depending on communication packets being sent and received. Control wiring to be provided by Contractor.
 2. Control wiring shall be installed in a daisy chain configuration. The remote controller wiring shall run from the indoor unit terminal block to the controller associated with that unit.
 3. Transmission (control) wiring between the indoor and outdoor unit shall be a maximum of 3,280 feet (total 6,560 feet).
 4. Transmission (control) wiring between the indoor unit and remote controller shall be a maximum distance of 1,640 feet.
- D. All control wiring shall be furnished and wired by the ATC Contractor.
- E. Electrical disconnects shall be furnished and wired by Div 26.

**CITY OF MERIDEN BOARD OF EDUCATION
ROGER SHERMAN ELEMENTARY SCHOOL
FIRST FLOOR NEW AIR CONDITIONING SYSTEM
MERIDEN, CONNECTICUT**

2.4 CONTROLS

A. General:

1. The VRV Controls Network is comprised of local remote controllers, advanced central controllers, and open protocol software devices that transmit information via the high-speed communication bus and may also be controlled via a network PC. The VRV Controls Network supports operation monitoring, scheduling, error e-mail distribution, general user software, tenant billing, maintenance support, and integration with Building Management Systems (BMS) using open protocol via BACnet®; all of which blend to provide the optimal control strategy for the best HVAC comfort solution. The systems shall have controls provided by Daikin to perform input functions necessary to operate the system.
2. Operation of the system shall permit either individual cooling or heating of each indoor unit simultaneously or all of the indoor units associated with each branch of the BS box. Each indoor unit or group of indoor units shall be able to provide set temperature independently via a local remote controller, an Intelligent Touch Manager or the central BMS.
3. Certain interior zones have been selected to operate in a low ambient cooling mode to -4F, while the remaining zones operate in heating. A simultaneous heating, cooling and low ambient cooling mode is desired for proper operation of the system. Manufacturer shall provide all needed accessories to accommodate this operation.
4. Each indoor unit or group shall be controlled by a factory provided, Navigation remote controller, capable of controlling up to 16 units.
5. The systems shall be furnished with a BACnet/IP Enabled Daikin Intelligent Touch Manager advanced centralized controller.
 - a. The controller will require 24VAC power.
 - b. The intelligent Touch Manager shall be equipped with two RJ-45 Ethernet ports for 100 Mbps network communication to support interconnection with a network PC via the Internet, Local Area Network (LAN), or connection with a non-networked PC after completed installation.
 - c. Web access functions shall be available so that facility staff can securely log into each Intelligent Touch Manager via the PC's web browser to support monitoring, scheduling, error recognition, downloading of system operation data (trend log (refer to pints list under bacnet server)) and general user functions. Error emails are also sent to designated email addresses.
 - d. Any software provided shall not have any licensing restrictions. If alternate manufacturer is selected having license restrictions, a 18-year license agreement must be included to the owner as part of this specification.
6. Global control over the entire system shall be managed from a central BMS including thermostat limits, space temperature and user functionality.
 - a. Through BACnet control from the ATC contractor, the indoor units shall be capable of automatic mode change over at set point plus 1F for cooling and set point minus 1F for heating.

2.5 MANUFACTURERS

A. Basis of design: **Daikin VRV**

- B. Alternate manufacturers that shall be considered are: Mitsubishi. No other manufacturers shall be considered.**
1. Any other manufacturer interested in bidding must provide full submittals – 2 weeks prior to bid – for review by the EOR. Scaled piping lengths, added refrigeration required and location of manufacturing must be included. Maximum levels of refrigerant required by the basis of design shall not be exceeded by an alternate manufacturer.

**CITY OF MERIDEN BOARD OF EDUCATION
ROGER SHERMAN ELEMENTARY SCHOOL
FIRST FLOOR NEW AIR CONDITIONING SYSTEM
MERIDEN, CONNECTICUT**

2. The mechanical contractor shall be responsible for all specified items and intents of this spec section and shall take full responsibility in accepting alternate/substituted manufacturer and any additional cost associated with providing the owner with fully operational system including electrical and considerations of higher refrigerant charge.

PART 3 -EXECUTION

3.1 INSTALLATION

1. Install units level and plumb.
2. Install evaporator-fan components using manufacturer's standard mounting devices securely fastened to building structure.
3. Install roof-mounted, compressor-condenser components on equipment supports. Anchor units to supports with removable, cadmium-plated fasteners.
 - i. Comply with requirements for vibration isolation and seismic control devices specified in Section 230548 "Vibration and Seismic Controls for HVAC."
4. Install and connect precharged refrigerant tubing to component's quick-connect fittings. Install tubing to allow access to unit.

3.2 FIELD QUALITY CONTROL

- i. **Manufacturer's Field Service:** Engage a factory-authorized service representative to inspect components, assemblies, and equipment installations, including connections, and to assist in testing.
5. **Tests and Inspections:**
 - i. **Leak Test:** After installation, charge system and test for leaks. Repair leaks and retest until no leaks exist.
 - ii. **Operational Test:** After electrical circuitry has been energized, start units to confirm proper motor rotation and unit operation.
 - iii. Test and adjust controls and safeties. Replace damaged and malfunctioning controls and equipment.
2. Remove and replace malfunctioning units and retest as specified above.
3. Prepare test and inspection reports.

3.3 STARTUP SERVICE

1. Engage a factory-authorized service representative to perform startup service.
 - i. Complete installation and startup checks according to manufacturer's written instructions.

**CITY OF MERIDEN BOARD OF EDUCATION
ROGER SHERMAN ELEMENTARY SCHOOL
FIRST FLOOR NEW AIR CONDITIONING SYSTEM
MERIDEN, CONNECTICUT**

3.3 DEMONSTRATION

1. Engage a factory-authorized service representative to train Owner's maintenance personnel to adjust, operate, and maintain units.

END OF SECTION 23 81 19

**CITY OF MERIDEN BOARD OF EDUCATION
ROGER SHERMAN ELEMENTARY SCHOOL
FIRST FLOOR NEW AIR CONDITIONING SYSTEM
MERIDEN, CONNECTICUT**

SECTION 26 00 00 - GENERAL ELECTRICAL

PART 1 - GENERAL

1.1 RELATED DOCUMENTS:

- A. The General Provisions of the Contract, including General and Supplementary Conditions and Division 1, General Requirements, apply to the work specified in this Section.
- B. The requirements in Section 260000 shall govern the work of all Sections of Division 26.

1.2 SCOPE OF WORK:

- A. Scope of work consists of installation of materials to be furnished under these Specifications and without limiting generality thereof consists of furnishing labor, materials, equipment, hoisting, plant, transportation, rigging, staging, appurtenances, and services necessary and/or incidental to properly complete all electrical work as shown on drawings, as described in the Specifications or as reasonably inferred from either as being required in opinion of the Engineer.
 - 1. Receptacles.
 - 2. Branch circuit wiring for receptacles and HVAC equipment.

1.3 SITE CONDITIONS:

- A. Prior to submitting bid, visit the site and identify existing conditions and difficulties that will affect work called for by the Contract Documents.
- B. No compensation will be granted for additional work caused by unfamiliarity with site conditions that are visible or readily construed by experienced observers. Include in the bid amount all demolition work required.
- C. The Contractor shall verify and obtain all necessary dimensions at the site.

1.4 DEFINITIONS:

- A. **Furnish:** The word "furnish" is used to mean "supply and deliver the referenced item to the project site, ready for unloading, unpacking, assembly, and installation".
- B. **Install:** The word "install" is used to describe operations at the project site involving the referenced item including the actual "unloading, unpacking, assembly, erection, placing, anchoring, applying, working to dimension, finishing, curing, protecting, cleaning, and similar operations".
- C. **Normally Occupied:** The words "normally occupied" are used to mean "all rooms within a building except for crawlspaces, underground tunnels, attic spaces, mechanical rooms, telephone rooms, data distribution rooms, and electrical rooms".

**CITY OF MERIDEN BOARD OF EDUCATION
ROGER SHERMAN ELEMENTARY SCHOOL
FIRST FLOOR NEW AIR CONDITIONING SYSTEM
MERIDEN, CONNECTICUT**

- D. Or Approved Equal: The words "or approved equal" are used to mean "any product which in the opinion of the Engineer is essentially equal in quality, size, arrangement, appearance, construction, and performance to that product specified or shown on the drawings".
- E. Provide: The word "provide" means "to furnish and install the referenced item, complete and ready for the intended use".
- F. Remove: The word "remove" means "to disconnect from its present position, remove from the project site, and to dispose of in a legal manner".

1.5 QUALITY ASSURANCE:

- A. Use adequate numbers of skilled workmen who are thoroughly trained and experienced in the necessary crafts and who are completely familiar with the specified requirements and the methods needed for proper performance of the work of the Contract Documents.
- B. Codes and Regulations:
 - 1. In addition to complying with the specified requirements, comply with all Federal, State and Local Codes wherever applicable including the following: 2022 Connecticut State Building Code, 2021 IBC, 2021 Connecticut Fire Safety Code , 2021 International Fire Code, 2019 NFPA 72 National Fire Alarm Code, 2020 NFPA 70 National Electrical Code as amended by the State Building Code , 2021 International Energy Conservation Code, ICC/ANSI A117.1-2009 Accessible and Usable Buildings and Facilities, and ADA.
 - 2. Comply with the requirements of the Local Authority Having Jurisdiction.
 - 3. Materials and equipment shall be UL listed where standard has been established.
 - 4. Perform tests required by specifications, Engineer's instructions, laws, ordinances or public authorities, approvals, and give Owner timely notice. Notify the Owner of dates for inspection by other authorities.
 - 5. In the event of conflict between or among specified requirements and pertinent regulations, the more stringent requirement will govern.
 - 6. Reference made to codes and standards shall be interpreted as minimum requirements. Provide and perform work in excess of codes and standards as indicated by drawings or specifications.
- C. Prior to bidding, the Contractor shall give written notice to the Engineer of any materials, equipment, or apparatus believed in the opinion of said Contractor, to be inadequate or unsuitable for the installation, or in violation of laws, ordinances, rules, or regulations of authorities having jurisdiction. The Contractor shall also give written notice to the Engineer of any items, materials, equipment, or work believed in the opinion of said Contractor, to be omitted from the Contract Documents. In the absence of such written notice, it is mutually agreed that Contractor has included the cost of all required items in his bid and that he will be responsible for approved satisfactory functioning of systems without further compensation.

1.6 SUBMITTALS:

- A. Refer to Division 20 for submittal procedures.

**CITY OF MERIDEN BOARD OF EDUCATION
ROGER SHERMAN ELEMENTARY SCHOOL
FIRST FLOOR NEW AIR CONDITIONING SYSTEM
MERIDEN, CONNECTICUT**

- B. Place a permanent label or title block on each submittal for identification. Indicate the name of the entity that prepared each submittal on the label or title block.
 - 1. Include the following information on the label for processing and recording action taken:
 - a. Project name, location, and address
 - b. Date
 - c. Name and address of Engineer
 - d. Name and address of Contractor
 - e. Name and address of Sub-Contractor
 - f. Name and address of supplier(s)
 - g. Name of manufacturer(s)
 - h. Number and title of appropriate Specification section.
- C. Data sheets and catalog cuts, etc. contained in submittals shall be clearly marked in ink indicating specific service or application for which material or equipment is to be used. Data of a general nature and not clearly defining the service or application for which the proposed item is to be used will not be accepted.
- D. Submit for review complete diagrams of systems prepared by equipment manufacturer showing connections and equipment. Standard wiring diagrams shall be modified where necessary to specific system.
- E. Prior to forwarding submittals and shop drawings for review by the Engineer, the Contractor shall thoroughly check each submittal, reject those not conforming to the specifications, and indicate by his signature that the submittals in his opinion meet the contract requirements.
- F. Intent of Shop Drawings and product data review is to check for capacity, rating and certain construction features, ensure that work meets requirements of Contract Documents regarding information that pertains to fabrication processes or means, methods, techniques, sequences and procedures of construction, and for coordination of work between trades.
- G. Submittal review shall not diminish responsibility under this contract for dimensional coordination, quantities, installation, piping, supports, access, service and errors, nor for deviations from requirements of contract documents. Noting errors while overlooking others will not excuse proceeding in error. Requirements of contract documents are not limited, waived, nor superseded by shop drawing review.
- H. Equipment variations: Where no specific make or material, apparatus or appliance is mentioned in the Contract Documents, any first class product made by a reputable manufacturer may be used, providing it conforms to the requirements of these specifications and meets the approval of the Engineer.
- I. Equipment alternates, substitutions, and deviations:
 - 1. Wherever more than one manufacturer is mentioned in the specifications or on the drawings, any of those named shall be considered equally acceptable to that on upon which design was based, and providing all aspects of the specification are met insofar as quality, construction, performance, space requirements, noise levels

**CITY OF MERIDEN BOARD OF EDUCATION
ROGER SHERMAN ELEMENTARY SCHOOL
FIRST FLOOR NEW AIR CONDITIONING SYSTEM
MERIDEN, CONNECTICUT**

- and special accessories or materials, any of those named may be included in Contractor's bid.
2. Bidders wishing to obtain approval on brands other than those specified by name shall submit their request to the Engineer not less than ten (10) business days before the date fixed for opening of bids. Approval by the Engineer will be in the form of an Addendum to the specifications issued to all prospective bidders, indicating that the additional brand or brands are approved as equal to those specified so far as the requirements of the project are concerned.
 3. Wherever a single manufacturer is used in the specifications or on the drawings and is followed by the words "or approved equal" the Contractor must use the item named or he may apply for an alternate equipment deviation through the prescribed manner in accordance with Item 1.6, I, 2.
 4. Alternate equipment to that specified or shown on the drawings, as proposed to be provided by the contractor, must be essentially equal in quality, size, construction, and performance to that item specified or shown on the drawings.
 5. Submittals for alternate equipment shall list all deviations and differences from the specified equipment. Failure to submit this list will result in rejection of the submittal. Any deviations and differences not listed but discovered after installation shall be rectified as directed by the Engineer at the Contractor's cost.
 6. Furnish samples of alternate equipment proposed to be provided when so requested by the Engineer.
 7. Where the Contractor proposes to use an item of equipment which differs from that upon which design was based, which requires any redesign of the structure, partitions, foundations, piping, wiring or of any other part of Mechanical, Electrical or Architectural Layout, all such redesign, new drawings or detailing required shall be prepared by Contractor at his own expense for approval of the Engineer.
 8. Where approved substitutions or deviations require a different quantity, size or arrangement of structural supports, wiring, conduit, piping, ductwork, and equipment from that upon which design was based, all additional items required by the systems shall, with the approval of the Engineer, be furnished by the Contractor at no additional cost to Owner.
- J. Allow sufficient time so that the delivery and installation of equipment will not be delayed as a result of the time required to review, process and transmit submittals, including resubmittals. Failure by the Contractor to transmit submittals to the Engineer in ample time for review and processing shall not entitle him to an extension of the Contract Time and no claim for an extension of time by reason of such default will be allowed.
- K. Submittals, shop drawings, and samples will be reviewed with reasonable promptness and will be stamped indicating appropriate action as follows:
1. "No Exceptions Taken" means that fabrication, manufacture, or construction may proceed providing submittal complies with contract documents.
 2. "Amend as Noted" means that fabrication, manufacture, or construction may proceed, providing the submittal complies with Engineer's notations and contract documents.
 3. "Resubmit" means that submittal, or equipment proposed to be provided, does not comply fully with the contract documents and that fabrication, manufacture, or

**CITY OF MERIDEN BOARD OF EDUCATION
ROGER SHERMAN ELEMENTARY SCHOOL
FIRST FLOOR NEW AIR CONDITIONING SYSTEM
MERIDEN, CONNECTICUT**

construction shall not proceed. Resubmit in accordance with the Engineer's notations and contract documents.

4. "Rejected" means that submittal does not comply with contract documents, or that equipment proposed to be provided does not comply with the specified requirements or is not equal or better in quality and performance than that item specified. Fabrication, manufacture, or construction shall not proceed. Resubmit in accordance with the contract documents and specified requirements.

- L. If material or equipment is installed prior to review, or without review, it shall be removed and replaced at no extra charge to the Owner if, in the opinion of the Engineer, the material or equipment is not in compliance with the Contract Documents.

1.7 AS-BUILT DRAWINGS:

- A. Maintain a clean, undamaged set of blue or black line white-prints of Contract Drawings and Shop Drawings at the job site. Protect record drawings from deterioration and loss in a secure location. Provide access to record drawings for the Engineer's reference during normal working hours.
- B. As work progresses mark the record drawings to show the actual installation where the installation varies from the work as originally shown, whether resulting from Addenda, Change Order, approved submittals, or changes made due to field conditions. Mark whichever drawing is most appropriate for showing conditions fully and accurately. Where shop drawings are used, record a cross reference at the corresponding location on the Contract Drawings. Give particular attention to items concealed within the structure or buried below grade.
 1. Mark as-built drawings with colored erasable pencils: using separate colors to distinguish between different systems.
 2. Include dimensioned locations of conduit runs buried below floor slabs and buried beyond the building footprint.
 3. Note related change order numbers where applicable.
- C. At the completion of work prepare a new set of black line white-print As-built Drawings, of work as actually installed, incorporating addenda, changes made due to approved submittals, change order work, field changes, and added data, all as shown on the marked-up record drawings maintained at the site. Date the set and clearly mark it as "As-built Drawings".
- D. Furnish two sets of the As-built Drawings to the Engineer for review and transmission to the Owner.

1.8 OPERATING AND MAINTENANCE MANUALS:

- A. Provide Operating and Maintenance Manuals in accordance with the requirements of Division 1 of these specifications.

**CITY OF MERIDEN BOARD OF EDUCATION
ROGER SHERMAN ELEMENTARY SCHOOL
FIRST FLOOR NEW AIR CONDITIONING SYSTEM
MERIDEN, CONNECTICUT**

1.9 GUARANTEE AND WARRANTIES:

- A. Comply with the requirements of Division 20.
- B. Obtain in Owner's name written equipment and material warranties offered in manufacturer's published product data without exclusion or limitation.
- C. Guarantee work of this Contract in writing for not less than eighteen (18) months from date of Substantial Completion. Repair or replace defective materials, equipment, workmanship and installation that develop within this period, promptly and to Owner's satisfaction and correct damage caused in making necessary repairs and replacements under guarantee within contract price.
- D. Replace material or equipment that requires excessive service during guarantee period, as defined and as directed by the Engineer.
- E. Submit guarantee to the Owner before final payment.

1.10 LAWS, ORDINANCES, PERMITS, AND FEES:

- A. Give all necessary notices, obtain all permits and pay all taxes, fees and other costs in connection with the work; file all necessary plans, prepare all documents and obtain all necessary approvals of all Regulation Authorities; obtain all required Certificates of Occupancy and/or Inspections required for the work and deliver same to the Owner before requests for acceptance and final payment for the work.
- B. Include in the work, without extra cost to the Owner, all labor, materials, services, apparatus, drawings (in addition to Contract Documents and Drawings) required to comply with all applicable laws, ordinances, rules and regulations.

1.11 CORRELATION OF DRAWINGS AND SPECIFICATIONS

- A. In general, the Specifications will describe the "quality" of the work and the drawings the "extent" of the work. The drawings and specifications are cooperative and supplementary; however, and each item of the work is not necessarily mentioned in both the drawings and specifications. All work necessary to complete the project, so described, is to be included in this contract.
- B. In case of disagreement between drawings and specifications, or within either document itself, the better quality or greater quantity of work shall be estimated and the matter drawn to the Engineer's attention for decision and/or adjustment. Any work done by any Contractor without consulting the Engineer, when the same requires a decision and/or adjustment, shall be done at the Contractor's risk.
- C. Drawings are diagrammatic and indicate general arrangement of systems and work included in Contract. Information and components shown on diagrams but not on plans, and vice versa, shall apply or shall be provided as though expressly required on both. It is not intended that every fitting or component be specified or shown on drawings; however,

**CITY OF MERIDEN BOARD OF EDUCATION
ROGER SHERMAN ELEMENTARY SCHOOL
FIRST FLOOR NEW AIR CONDITIONING SYSTEM
MERIDEN, CONNECTICUT**

Contract Documents require provision of all components and materials necessary for a complete and operational installation, whether or not indicated or specified.

- D. Do not scale drawings. Scale indicated on drawings is for establishing reference points only. Actual field conditions shall govern all dimensions. The Contractor shall verify all dimensions at the project site.
- E. In all cases where the Contract Documents refer to equipment or apparatus in singular number, it is intended that such reference include as many such items that are required to complete the work.

1.12 ELECTRICAL VOLTAGES:

- A. The electrical services to the buildings is 208Y/120V, 3 phase, 4 wire, 60Hz.
- B. All equipment shall be suitable for this electrical supply. It is the responsibility of the Contractor to study the electrical drawings to determine the supply for any particular piece of equipment.
- C. If equipment requires other electrical characteristics (voltage and phase) than that supplied and shown on the electrical drawings, transformers and wiring shall be provided with that equipment at no extra cost to the Owner.

PART 2 - PRODUCTS

2.1 MATERIALS AND WORKMANSHIP:

- A. Provide only materials that are new and of type and quality specified. Where Underwriters' Laboratories, Inc. have established standards for such materials, provide only materials bearing the UL label.
- B. Provide accessories, materials and equipment necessary to make installation complete in every detail, and to conform to manufacturers' latest installation instructions, under this Contract whether or not specifically shown on drawings or specified herein.
- C. All component parts of each item of equipment shall bear the manufacturers' nameplate, giving name of manufacturer, description, size, type, serial or model number, electrical characteristics, etc. in order to facilitate maintenance or replacement. Contractors or Distributors nameplates shall not be fixed to items of equipment and are not an acceptable alternate to the manufacturer's nameplate data.
- D. No materials or equipment used shall be discontinued or about to be discontinued items.
- E. The Engineer shall have the right to reject any part of the work in case the material or workmanship is not of satisfactory quality. Any work or material deemed unacceptable by the Engineer shall be removed and replaced with acceptable work and material as defined by the Engineer, and at no additional expense to the Owner.

**CITY OF MERIDEN BOARD OF EDUCATION
ROGER SHERMAN ELEMENTARY SCHOOL
FIRST FLOOR NEW AIR CONDITIONING SYSTEM
MERIDEN, CONNECTICUT**

2.2 PROTECTION:

- A. Work performed by the Contractor shall include protecting the work and materials of all other Contractors from damage by work or workmen, and shall include making good any and all damage thus caused.
- B. The Contractor shall be responsible for work and equipment until finally inspected, tested and accepted. Protect work against theft, weather, injury or damage, and carefully store material and equipment received on site which is not immediately installed. Close open ends of work with approved covers, caps or plugs during construction to exclude dust, dirt, moisture, plaster, mortar, or general construction debris. Note - duct tape is not an acceptable means of protecting open conduit and pipe ends.
- C. If so specified, work may include receiving, unloading, uncrating, storing, protecting, setting in place and completely connecting any motor starters and/or control equipment having mechanical/electrical service connections which may be furnished by Owner or furnished by others.
- D. Work shall include exercising special care in handling and protecting equipment and fixtures. Any equipment and fixtures which are missing, lost, stolen, or damaged by reason of the Contractor's failure to provide adequate protection shall be replaced by that Contractor at no additional cost to the Owner.

2.3 TEMPORARY FACILITIES:

- A. Provide temporary power, lighting, and communications as required for the performance of the work of this Contract.
- B. Provide new materials and equipment; if acceptable to the Engineer, undamaged previously used materials in serviceable condition may be used. All materials shall be suitable for the service intended.
- C. Maintain temporary services and facilities in a neat and clean manner. Operate in a safe and efficient manner. Do not allow hazardous, dangerous, or unsanitary conditions to develop or persist on site.
- D. Do not overload temporary facilities, or permit them to interfere with progress of the work.
- E. Scaffolding and other temporary construction shall be rigidly built in accordance with Local, State, and Federal regulations.
- F. Remove each temporary facility when no longer needed, when replaced by authorized use of a permanent facility, or no later than Substantial Completion. Complete and/or restore permanent construction that may have been delayed because of interference with the temporary facility. Repair damaged work, clean exposed surfaces, and replace construction that cannot be repaired to the satisfaction of the Owner.

**CITY OF MERIDEN BOARD OF EDUCATION
ROGER SHERMAN ELEMENTARY SCHOOL
FIRST FLOOR NEW AIR CONDITIONING SYSTEM
MERIDEN, CONNECTICUT**

2.4 SCAFFOLDING, RIGGING, HOISTING:

- A. Work shall include all scaffolding, rigging, hoisting and services necessary for delivery and erection of equipment into or onto the site and/or building. Remove all scaffolding, rigging, and hoisting equipment from the site when no longer needed.

2.5 EXCAVATION AND BACKFILLING:

- A. Excavation and backfilling for all electrical work inside and outside of the building shall be performed in accordance with Division 2 of these Specifications.

2.6 CUTTING AND PATCHING:

- A. Cutting and patching for all electrical work shall be performed in accordance with Division 1 of these Specifications.

2.7 SLEEVES AND OPENINGS:

- A. The Electrical Contractor shall provide all necessary sleeves and openings as required to permit the installation of the electrical systems.

2.8 PAINTING:

- A. All painting of electrical work shall be performed in accordance with Division 9 of these Specifications, unless otherwise specified.

2.9 ELECTRICAL MOTOR STARTERS AND VARIABLE FREQUENCY DRIVES (VFD'S):

- A. Motor starters and variable frequency drives (VFD'S) shall be furnished by each respective trade for motor driven equipment provided by them. The Electrical Contractor shall install the starters and VFD'S, and shall provide all power wiring to the starters and VFD'S, and from the starters and VFD'S to the motors they control.
- B. Motor starters and VFD'S shall conform to requirements of NEC, NEMA, UL, CSA, and ANSI and shall be suitable for the required horsepower, duty, voltage, phase, frequency, service, and location. All starters and VFD'S shall be furnished in NEMA enclosures suitable for the environment in which they are to be located.
- C. All starters shall be of the same manufacture and shall be furnished in Square D, Cutler-Hammer, General Electric, or Allen Bradley.
- D. Thermal Overloads:
 - 1. All motors 1/8 horsepower or larger shall be provided with thermal-overload protection. Thermal overloads shall be melting alloy ambient temperature compensating type.
 - 2. Thermal overloads shall be sized in accordance with NEC requirements for the nameplate data of the motor(s) as actually delivered to the site.

**CITY OF MERIDEN BOARD OF EDUCATION
ROGER SHERMAN ELEMENTARY SCHOOL
FIRST FLOOR NEW AIR CONDITIONING SYSTEM
MERIDEN, CONNECTICUT**

- E. Starters for manual control of single phase motors up to one (1) horsepower furnished without integral thermal overloads shall be combination manual disconnect switch and starters with thermal overload protection for each ungrounded leg. Starters shall be inoperable if a thermal unit is removed. These starters shall be 2-pole and shall be provided with green neon pilot light and handle guard/lock-off.
- F. Starters for three phase motors shall be full voltage, circuit breaker combination magnetic starters. All circuit breaker combination magnetic starters shall include melting alloy type thermal overload protection, low voltage protection, and two (2) sets of auxiliary normally open and normally closed contacts. Thermal overload protection shall be provided in each ungrounded leg. Starters shall be inoperable if a thermal unit is removed. All circuit breaker combination magnetic starters shall be equipped with control power circuits. Provide starters with control power transformers of secondary voltage required for the control power circuitry. Provide control power transformers with primary and secondary fusing. The disconnect handle on circuit breaker combination magnetic starters shall always be in control of the disconnect device with the door opened or closed. The disconnect handle shall be clearly marked as to whether the disconnect device is "on" or "off", and shall include a two-color handle grip, the black side visible in the "off" position, and the red side visible in the "on" position.
 - 1. All circuit breaker combination magnetic starters for manual control of three phase motors shall have start-stop push buttons in the cover and shall be provided with red and green pilot lights.
 - 2. All circuit breaker combination magnetic starters for automatic or interlocking control of three phase motors shall have hand-off-automatic selector switches in the cover and shall be provided with red and green pilot lights.

2.10 BASES AND SUPPORTS:

- A. Provide all necessary supports, rails, framing, bases, and piers required for the installation of equipment provided under this contract.
- B. Unless otherwise shown, all equipment shall be securely attached to the building structure in an acceptable manner. Attachments shall be of a strong and durable nature; any attachments that are insufficient in the opinion of the Engineer shall be replaced as directed at no additional cost to the Owner.

2.11 SEISMIC RESTRAINTS:

- A. Provide seismic restraints for all electrical system components in accordance with the 2016 Connecticut State Building Code.

2.12 SLEEVES, INSERTS AND ANCHOR BOLTS:

- A. The Contractor shall provide and shall be held responsible for the location and position of all sleeves, inserts, and anchor bolts required by his work. Failure to do so, which requires cutting and patching of finished work, shall be done at no additional cost to the Owner.

**CITY OF MERIDEN BOARD OF EDUCATION
ROGER SHERMAN ELEMENTARY SCHOOL
FIRST FLOOR NEW AIR CONDITIONING SYSTEM
MERIDEN, CONNECTICUT**

2.13 FIRE STOPPING:

- A. Fire stopping work shall be done under Division 20 of these specifications.

2.14 LUBRICATION:

- A. All equipment installed under this contract having moving parts shall and requiring lubrication shall be properly lubricated according to the manufacturer's instructions prior to operation and testing. Any such equipment discovered to have been operated prior to lubrication by the Contractor shall be subject to rejection and replacement at no additional cost to the Owner.

2.15 ACCESS PANELS:

- A. Provide access panels for electrical equipment which is not readily accessible. Such equipment includes items above hung ceilings which are not readily removable and items installed within walls, inside chases, or inside dead cavity spaces.
- B. Access panels shall be of sufficient size to permit easy replacement and servicing of electrical equipment.
- C. Access panels shall bear the same or greater fire rating as the wall or ceiling in which they are installed.

2.16 OTHER MATERIALS:

- A. Provide other materials, not specifically described but required for a complete and proper installation, as selected by the Contractor subject to the approval of the Engineer.
- B. Provide miscellaneous hardware and support accessories, including channels, support rods, nuts, bolts, screws, and other such items, with galvanized or cadmium plated finish, or other approved rust inhibiting coatings.

PART 3 - EXECUTION

3.1 GENERAL:

- A. Unless specifically noted or shown otherwise, install all equipment and material specified herein or shown on drawings whether or not specifically itemized herein.

3.2 SURFACE CONDITIONS:

- A. Examine the areas and conditions under which work of this Contract will be performed. Correct conditions detrimental to timely and proper completion of the work. Do not proceed until unsatisfactory conditions are corrected.

**CITY OF MERIDEN BOARD OF EDUCATION
ROGER SHERMAN ELEMENTARY SCHOOL
FIRST FLOOR NEW AIR CONDITIONING SYSTEM
MERIDEN, CONNECTICUT**

3.3 PREPARATION:

A. Coordinate:

1. Coordinate as necessary with other trades to assure proper and adequate provisions in the work of those trades for interface with the work of this Contract. Each Contractor shall furnish all information necessary to permit work of other trades to be installed in a satisfactory manner.
2. Coordinate delivery of equipment to project prior to installation. Any equipment stored for an extended period of time prior to installation may be subject to rejection by the Owner or Engineer.
3. Coordinate the installation of items with the schedule for work of other trades to prevent unnecessary delays in the total work.
4. Where electrical equipment is shown in conflict with locations of structural members or other equipment, provide required supports, offsets, bends, or tees as required to clear the encroachment.
5. No conduit, cable(s), boxes, etc., shall be installed until the entire run has been checked for clearances and the work has been coordinated between all the trades. Each tradesman shall be responsible for taking his own field measurements and maintaining proper clearance from the Owner's equipment and the work of other trades, and for coordinating his work with that of other Contractors. Furnish all necessary information, dimensions, templates, etc. in order that a properly coordinated job will result.
6. Prior to roughing, the contractor shall obtain exact electrical equipment, fixture, and device locations from the Owner. Equipment, fixture, and device locations shown on the drawings are to be used for general reference only. Roughing of equipment, fixtures, and devices shall not proceed until the exact locations, heights, and orientations of same have been agreed upon with the Owner.
7. If due to lack of coordination and foresight by the Contractor, equipment must be relocated or extra work performed, all costs shall be the responsibility of the Contractor and may not be passed through to the Owner.

B. Unload equipment and materials delivered to the site. Pay cost for rigging, hoisting, lowering and moving electrical equipment on site, in building, or on roof. During construction provide protection against moisture, dust accumulation, and physical damage of equipment. Provide temporary heaters within units as required to evaporate excessive moisture and provide ventilation as required.

C. Certain present building clearances are available for handling equipment. All equipment shall be delivered knocked down as required to clear space limitations on site and within the building.

D. Unless noted otherwise the Contractor shall set all equipment level, plumb, and secure prior to making connections to other equipment or systems.

**CITY OF MERIDEN BOARD OF EDUCATION
ROGER SHERMAN ELEMENTARY SCHOOL
FIRST FLOOR NEW AIR CONDITIONING SYSTEM
MERIDEN, CONNECTICUT**

- E. Data indicated on the drawings and in these Specifications are as exact as could be secured, but their absolute accuracy is not warranted. The exact locations, distances, levels and other conditions will be governed by actual construction and the drawings and specifications should be used only for guidance in such regard.
- F. Verify all measurements at the building. No extra compensation will be allowed because of differences between work shown on the drawings and actual measurements at the site of construction.
- G. The drawings are diagrammatic, but are required to be followed as closely as actual construction and work of other trades will permit. Where deviations are required to conform with actual construction and the work of other trades, make such deviations without additional cost to the Owner.

3.4 ACCESSIBILITY:

- A. Locate all equipment which must be serviced, operated or maintained, in fully accessible positions including but not limited to: controllers, motor starters, disconnect switches, transformers, panelboards, switchgear, etc. Provide access panels as required for equipment access.
- B. Failure by the Contractor to locate equipment and arrange the installation to allow for adequate access and clearance for maintenance and servicing shall result in rejection of the installation and the disassembly, relocation and re-assembly of the installation shall be done by the Contractor at no additional cost to the Owner.

3.5 CLEANING AND PROTECTING PIPING, CONDUITS AND EQUIPMENT:

- A. Thoroughly clean all piping, conduit, and equipment of all foreign substances inside and out before installation.
- B. Plug open pipe and conduit ends during construction with approved plugs or caps to exclude dust, moisture, plaster or mortar etc. Note - using duct tape to cover conduit and pipe ends is not an acceptable means of excluding construction debris and may result in rejection of the installation with remedial action to be taken by the Contractor at no additional cost.
- C. If any part of a conduit system should be blocked by any foreign matter after being placed in operation, the system shall be disconnected, cleaned and reconnected wherever necessary in order to locate and remove the obstruction(s). Any work damaged in the course of removing obstructions shall be repaired or replaced at no additional cost to the Owner.

3.6 TESTING AND INSPECTION:

- A. Provide personnel and equipment, make required tests, and secure required approvals from governmental agencies having jurisdiction.

**CITY OF MERIDEN BOARD OF EDUCATION
ROGER SHERMAN ELEMENTARY SCHOOL
FIRST FLOOR NEW AIR CONDITIONING SYSTEM
MERIDEN, CONNECTICUT**

- B. When material and/or workmanship is found to not comply with the specified requirements, within three days after receipt of notice of such non-compliance remove the non-complying items from the job site and replace them with items complying with the specified requirements, all at no additional cost to the Owner.
- C. Perform all required adjustments and settings. Verify and correct any deficiencies as required.
- D. Provide all necessary testing equipment.
- E. In the Owner's Presence:
 - 1. Test all parts of the electrical system and prove that all such items provided under this Specification function electrically in the required manner.

3.7 PROJECT COMPLETION:

- A. Upon completion of the work, remove all waste, rubbish and other materials left as a result of operations and leave the premises in clean condition.
- B. Thoroughly clean all exposed portions of the mechanical and electrical installations, removing all traces of soil, labels, grease, oil and other foreign material, and using only the type cleaner recommended by the manufacturer of the item being cleaned.
- C. Vacuum all exteriors of equipment and interiors of equipment having accessible interior compartments to remove all dust, dirt, cable clippings, construction debris, etc.
- D. Equipment with damage to painted finish shall be repaired to satisfaction of the Owner.
- E. Upon completion of all work and of all tests, the Contractor shall furnish the necessary skilled labor and helpers for operating the system and equipment for a period of one (1) day or eight (8) hours, or as otherwise specified. During this period, instruct the Owner or his representative fully in the operation, adjustment and maintenance of all equipment furnished. Give at least forty-eight (48) hours' notice to the Owner in advance of this period.
- F. Thoroughly indoctrinate the Owner's operation and maintenance personnel in the contents of the record drawings and the operations and maintenance manual required to be submitted under these Specifications.

3.8 INSTRUCTION PERIOD:

- A. Prepare written instruction frames for the proper maintenance and operation of any special equipment furnished and installed under this Contract.
- B. The contractor shall arrange for on-site instruction of the Owner's representatives by manufacturers of all major items of equipment. The instruction periods shall be consecutive and shall be held after the installations are complete, tested and balanced and the approved documentation is available. The contractor shall be responsible for

**CITY OF MERIDEN BOARD OF EDUCATION
ROGER SHERMAN ELEMENTARY SCHOOL
FIRST FLOOR NEW AIR CONDITIONING SYSTEM
MERIDEN, CONNECTICUT**

attendance of the manufacturer's technical representatives and shall coordinate program timing with the Owner.

- C. In addition to normal operation, the Owner's representatives shall be instructed on routine maintenance and trouble-shooting.

END OF SECTION 26 00 00

**CITY OF MERIDEN BOARD OF EDUCATION
ROGER SHERMAN ELEMENTARY SCHOOL
FIRST FLOOR NEW AIR CONDITIONING SYSTEM
MERIDEN, CONNECTICUT**

SECTION 26 05 00 - BASIC ELECTRICAL MATERIALS & METHODS

PART 1 - GENERAL

1.1 RELATED DOCUMENTS:

- A. The Bidding Requirements, Contract Forms and Conditions of the Contract, including General Conditions of the Contract for Construction, and Division 1 - General Requirements, apply to the work specified in this Section.
- B. Sections 200050 General Conditions, and 260000 General Electrical, shall also govern the work under this Section.
- C. This Section includes requirements that are binding on other Sections of Division.
- D. Examine all drawings, data, and coordinate the work of this Section with all related and adjoining work.

1.2 SCOPE:

- A. Scope of work consists of installation of materials to be furnished under this Section, and without limiting generality thereof consists of furnishing labor, materials, equipment, hoisting, plant, transportation, rigging, staging, appurtenances, and services necessary and/or incidental to properly complete all electrical work as shown on the drawings, as described in these specifications or as reasonably inferred from either as being required in opinion of the Owner.
- B. Work Included: Provide complete electrical services where shown on the drawings, as specified herein and as needed for a complete and proper installation including but not necessarily limited to:
 - 1. General
 - 2. Conduits & Raceways
 - 3. Equipment Labeling
 - 4. Wire and Cables
 - 5. Receptacles
 - 6. Outlet Boxes, Junction Boxes, Pull Boxes
 - 7. Cabinets
 - 8. Disconnect Switches
 - 9. Supporting Devices
 - 10. Grounding
 - 11. Backboards

1.3 QUALITY ASSURANCE:

- A. Refer to Section 260000.

**CITY OF MERIDEN BOARD OF EDUCATION
ROGER SHERMAN ELEMENTARY SCHOOL
FIRST FLOOR NEW AIR CONDITIONING SYSTEM
MERIDEN, CONNECTICUT**

1.4 SUBMITTALS:

- A. Shop Drawings: Submit for all items listed in Paragraph 1.2.B.

PART 2 - PRODUCTS

2.1 GENERAL:

- A. Provide only materials that are new and of type and quality specified, or approved equal. Where Underwriters' Laboratories, Inc. have established standards for such materials, provide only materials bearing the UL label.
- B. Provide materials and equipment necessary to make installation complete in every detail, and to conform to manufacturers' latest installation instructions, under this contract whether or not specifically shown on drawings or specified herein.

2.2 TEMPORARY FACILITIES:

- A. Scaffolding and other temporary construction shall be rigidly built in accordance with Local and State requirements. Remove from premises upon completion of work.
- B. Provide temporary construction required for electrical work as directed by the Architect and Engineer.

2.3 RACEWAYS:

A. Rigid Steel Conduit:

1. Shall be manufactured from high strength strip steel, shall be hot dipped galvanized with threads galvanized after cutting, and shall be chromated to form an additional protective layer. Rigid steel conduits shall be UL listed, shall meet the requirements of ANSI C80.1, and shall be as manufactured by Allied Tube and Conduit, Wheatland, or Calconduit.
2. Shall be used in outdoor locations where conduit is exposed to physical damage, sunlight or weather.
3. Shall be used for underground work.
4. Shall be used for horizontal and vertical underground sweeps, horizontal and vertical sweeps below concrete slabs, and for penetrations through concrete slabs.
5. Fittings, couplings and connectors shall be threaded and galvanized or cadmium plated.

B. Rigid PVC Conduit:

1. Shall be heavy wall schedule 40 PVC for underground work and extra heavy wall schedule 80 PVC for underground work below vehicular traffic areas. Joints and fittings shall be solvent welded all to ASTM standards for underground installation and in accordance with Article 352 of the National Electric Code.

**CITY OF MERIDEN BOARD OF EDUCATION
ROGER SHERMAN ELEMENTARY SCHOOL
FIRST FLOOR NEW AIR CONDITIONING SYSTEM
MERIDEN, CONNECTICUT**

2. May be used in lieu of rigid steel conduit for underground work except as noted in paragraph 2.3, A, 4 above.
3. The minimum size for running below slabs shall be 1 1/4" for both feeders and branch circuits.
4. Joints shall be made watertight.
5. Shall not be embedded in concrete slabs.
6. Shall not be used above ground.
7. Shall not be used for underground horizontal and vertical sweeps, horizontal and vertical sweeps below concrete slabs, or for penetrations through concrete slabs.
8. Furnish conduit system in Prime, Cantex, or JM Eagle.
9. Flexible PVC conduit (ENT) shall not be used.

C. Intermediate Steel Conduit:

1. Shall be manufactured from high strength flat steel that is cold-formed and electrically welded into a uniform tube, shall be hot dipped galvanized with threads galvanized after cutting, and shall be chromated to form an additional protective layer. Intermediate steel conduit shall be UL listed, shall meet the requirements of ANSI C80.6, and shall be as manufactured by Allied Tube and Conduit, Wheatland, or Calconduit..
2. Shall be used in interior locations where conduit is exposed to physical damage, or corrosive or wet environments.
3. Fittings, couplings and connectors shall be threaded and galvanized or cadmium plated.

D. Electrical Metallic Tubing:

1. Shall be manufactured from high grade mild strip steel, shall be hot dipped galvanized, and shall be chromated and lacquered to form additional protective layer. EMT conduit shall conform to UL 797 and ANSI C80.3 and shall be as manufactured by Allied Tube and Conduit, Wheatland, or Calconduit.
2. Connectors and couplings shall be galvanized steel set screw type. Provide gland compression type couplings and connectors for exposed work in wet locations.
3. Shall be used for all interior feeders except where noted differently on the drawings. Provide insulated throat grounding bushings for all feeder conduit connections to switchboards, panelboards, disconnect switches, wireways, and pull boxes.
4. Shall be used for all interior wiring in masonry partitions, above non-accessible ceilings, and where exposed to view.
5. Shall be used for all branch circuit homeruns and closing connections to panelboards. Do not use Type 'MC' cable for wiring exposed to view, in masonry partitions, above non-accessible ceilings, or for branch circuit homeruns.
6. Shall be used for all branch circuits feeding HVAC equipment and equipment requiring 3-Phase power.
7. Shall not be embedded in concrete slabs.

E. Flexible Steel Conduit:

1. Shall be full wall steel flexible conduit, shall be manufactured from high grade strip steel and shall be hot dipped in a molten zinc bath. The steel strip shall be

**CITY OF MERIDEN BOARD OF EDUCATION
ROGER SHERMAN ELEMENTARY SCHOOL
FIRST FLOOR NEW AIR CONDITIONING SYSTEM
MERIDEN, CONNECTICUT**

formed into interlocking convolutions that are continuously joined, metal to metal, assuring continuous grounding contact. Flexible steel conduit shall be UL listed and shall be as manufactured by AFC Cable Systems, Greenfield, Anaconda, or Electri-Flex.

2. Flexible steel conduit fittings shall be zinc plated malleable iron squeeze type connectors and zinc plate malleable iron combination couplings
3. May be used in short lengths where EMT cannot be installed due to interferences and obstacles.
4. Provide for final connections to motor driven equipment, transformers, recessed light fixtures, chain hung light fixtures, or where subject to vibration.

F. Liquidtight Flexible Steel Conduit:

1. Shall be similar to flexible steel conduit, but with pressure-extruded moisture and oil-proof outer jacket of gray polyvinyl chloride plastic. Liquidtight flexible steel conduit shall be UL listed (UL 360) and shall be as manufactured by AFC Cable Systems, Anaconda, or Electri-Flex.
2. Fittings, couplings and connectors shall be threaded, zinc plated, malleable iron liquidtight type.
3. Provide where located outdoors or in damp or wet areas for final connections to motor driven equipment, or where subject to vibration.
4. Do not use in environmental air plenum spaces.

G. Sleeves:

1. Provide EMT sleeves for each conduit and cable passing through interior walls, partitions, and floors.
 - a. Set pipe sleeves in place before wall, floor, or partition is finished.
 - b. Support conduit and cable free from sleeves.
 - c. Provide sleeves two pipe sizes larger than the conduit or cable passing through, or provide a minimum of ½" clearance.
2. Provide chrome plated escutcheon plates for each sleeve where exposed to view in finished areas.
3. Provide GPT Industries WSG galvanized steel wall sleeves for each conduit passing through foundation walls. Galvanized steel wall sleeves shall be schedule 40 steel pipe in sizes through 10" diameter and shall have a 0.375" wall thickness for sizes 12" diameter and larger. WSG galvanized steel wall sleeves shall have a 2" collar (water stop) at the mid-point of the sleeve. The 2" collar shall be continuously welded on both sides to the sleeve. Provide GPT Industries Link-Seal modular waterproof seals at all foundation wall sleeves. Where penetrating existing foundation walls provide a core drilled penetration and Link-Seal modular waterproof seal without the galvanized steel wall sleeve.

H. Surface Steel Wireway:

1. Wireways shall be code gauge galvanized steel, manufactured standard sections and fittings, with hinged and/or screw covers, indoors NEMA Type 1/Outdoors NEMA Type 3R, and shall be manufactured by Hoffman, Cooper, Square D, or Wiremold. Wireways shall be sized to code conductor fill requirements and shall be provided as required for job conditions.

**CITY OF MERIDEN BOARD OF EDUCATION
ROGER SHERMAN ELEMENTARY SCHOOL
FIRST FLOOR NEW AIR CONDITIONING SYSTEM
MERIDEN, CONNECTICUT**

2.4 METHODS AND MATERIALS FOR LABELING EQUIPMENT:

- A. Safety Switches:
 - 1. Non-metallic engraved nameplates shall be used to identify device. Nameplates shall be secured to equipment with two screws or rivets.
 - 2. Letters to be white on black background.
 - 3. Nameplate letters to be 1/4" high.
 - 4. Identification nomenclature shall be in accordance with plans. All name nomenclature shall be submitted for approval.
- B. Identify all fused disconnect switches with installed fuse size, i.e: Maximum fuse size = xxx amps. Identification shall be of the same method as specified in paragraph 2.4.A, except white letters on red background.
- C. Identify the covers of all junction boxes and pull boxes installed above ceilings and in unfinished spaces with branch circuit or feeder designations. Identification shall be done with black felt tip permanent marker in a neat and readily legible manner.
- D. Provide a typewritten adhesive label with an identification legend at the switchboard and at each panelboard identifying the color coding of the ungrounded conductors being supplied by the switchboard and each panelboard.
- E. Indexing and Identification: After installations are complete, provide and mount under sturdy transparent shield in the directory frame of each panel door a neat, accurate and carefully typed directory properly identifying the lighting, receptacles, outlets, equipment and rooms which each branch circuit breaker controls.

2.5 SAFETY SWITCHES:

- A. All safety disconnect switches shall be furnished in heavy duty quick-make, quick-break, interlocking fusible or non-fusible, type as indicated on the drawings. Manufacturer shall be the same as provided for switchgear and panelboards.
- B. Provide enclosures clearly marked for maximum voltage, current and horsepower rating, and:
 - 1. Indoors: NEMA Type 1.
 - 2. Outdoors or Damp or Wet Locations: NEMA Type 3R.
 - 3. Hosedown and Splashing Water Locations: NEMA Type 4.
- C. Furnish and install disconnect switches at each motor location except where combination switches and starters are furnished with equipment by others but are mounted by this contractor.
- D. Furnish and install weatherproof disconnect switch at each exterior located fan or motor location.
- E. Disconnect switches shall be of "lock-out" design to prevent opening of switch when in "ON" position.

**CITY OF MERIDEN BOARD OF EDUCATION
ROGER SHERMAN ELEMENTARY SCHOOL
FIRST FLOOR NEW AIR CONDITIONING SYSTEM
MERIDEN, CONNECTICUT**

2.6 MOTOR STARTER/DISCONNECTS AND VFD'S:

- A. Combination motor starter/disconnects and variable frequency drives (VFD's) will be supplied by other trades for motor driven equipment provided by them.
- B. The electrical contractor shall install the starter/disconnects and VFD's, and shall provide all power wiring to the units and from the units to the motors they control.

2.7 CONDUCTORS:

- A. Conductors shall be provided in Cerro Wire Manufacture or comparable product in Southwire or Republic Wire.
- B. All feeder conductors shall be copper rated 600 volts, 90 deg. C., dry and wet locations, Type XHHW-2, color coded.
- C. All branch lighting and power conductors shall be copper rated 600 volts, 90 deg. C., dry and wet locations, Type XHHW-2, color coded.
- D. Grounding electrode conductors and bonding conductors shall be soft drawn copper, ASTM B3 solid bare copper for sizes smaller than #8AWG, ASTM B8 concentric stranded bare copper for sizes #8AWG and larger.
- E. Minimum gauge conductors shall be #12 AWG. Increase to #10 AWG for runs exceeding 75'-0", and #8AWG for runs exceeding 150'-0".
- F. Wire Size #8 AWG and larger shall be stranded. Wire of size smaller than #8 AWG shall be solid.
- G. Wire and cable conductors shall be soft drawn copper with conductivity of not less than 98 percent of ANSI Standard for annealed copper. Aluminum conductors shall not be used.
- H. Type 'MC' Cable:
 - 1. Shall be a factory assembly of copper type 'THHN' conductors including a green insulated equipment grounding conductor, with a mylar tape overall assembly covering, housed in a continuous interlocking galvanized steel sheath. Provide with optional insulated bushings.
 - 2. May only be used in dry locations for single phase lighting and receptacle branch circuit wiring where concealed from view above accessible ceilings or in stud walls.
 - 3. Shall not be used in damp or wet locations, where exposed to view, in masonry walls, above non-accessible ceilings, for HVAC equipment, for equipment requiring 3-phase power, for branch circuit homeruns, or for closing connections to panelboards.
 - 4. Shall be as manufactured by AFC Cable Systems, Southwire, or CME.
 - 5. Metal clad cable connectors shall be malleable iron set screw type connectors.

**CITY OF MERIDEN BOARD OF EDUCATION
ROGER SHERMAN ELEMENTARY SCHOOL
FIRST FLOOR NEW AIR CONDITIONING SYSTEM
MERIDEN, CONNECTICUT**

2.8 OUTLET, JUNCTION AND PULL BOXES:

- A. Provide outlet boxes as required for a complete installation.
- B. Outlet boxes for flush (concealed) work shall be code gauge galvanized steel and shall be of shapes and sizes to suit their respective locations and installations, and shall be provided with covers to suite their function and installation. Outlet boxes shall be equipped with fixture stud or straps where required.
- C. The minimum box size for all flush wall outlet boxes shall be nominal 4 11/16" square x 2 1/8" deep (2-gang) except where noted differently on the drawings. Provide larger size outlet boxes, or gangable type boxes where required for the installation.
- D. For lighting outlets, provide standard 4" octagon units with 4" round flat covers. Provide 3/8" malleable iron fixture studs and box hangers where required. For lighting fixtures make final connection with flexible conduit of sufficient length to allow fixtures to be repositioned.
- E. Surface mounted boxes for switches and receptacles shall be 1-1/2" minimum deep.
- F. For exposed work, provide drawn-type boxes with galvanized steel crushed corner exposed work covers. Provide cast boxes for work exposed to wet locations and where called for on the drawings.
- G. For above ground pull boxes, provide galvanized code-gauge sheet steel units with screwed on covers, of size and shape required to accommodate wires without crowding, and to suit the location. Provide pull boxes as specified herein, as required for job conditions, and as follows:
 - 1. Indoors: NEMA Type 1.
 - 2. Outdoors or Damp or Wet Locations: NEMA Type 3R.
 - 3. Hosedown and Splashing Water Locations: NEMA Type 4.

2.9 WIRING DEVICES:

- A. All devices shall be furnished in Hubbell or comparable product in Cooper or Leviton. Devices specified herein are based on Hubbell unless otherwise noted. Device colors shall be as directed by the Engineer.
- B. Lighting Switches:
 - 1. Toggle Type: Institutional Heavy Duty specification grade, flush mounting, quiet operation AC type with abuse resistant colored nylon toggle operator, heat resistant composition plastic housing, silver cadmium oxide contacts and copper alloy spring contact arm. Rated at 120-277 VAC, capable of full capacity on tungsten or fluorescent lamp load. Designed for side or back wiring with up to No. 10 wire, and with #8 brass terminal screws.

**CITY OF MERIDEN BOARD OF EDUCATION
 ROGER SHERMAN ELEMENTARY SCHOOL
 FIRST FLOOR NEW AIR CONDITIONING SYSTEM
 MERIDEN, CONNECTICUT**

	<u>20 AMP</u>	<u>30 AMP</u>
Single Pole	#HBL1221	#HBL3031
Two Pole	#HBL1222	#HBL3032
Three way	#HBL1223	#HBL3033
Four way	#HBL1224	-

- Switch with lighted toggle pilot or pilot light toggle: same as toggle type except with clear polycarbonate lighted toggle(light on with load off) or red polycarbonate pilot light toggle (light on with load on).

	<u>20 AMP</u>	<u>30 AMP</u>
Lighted Toggle	#HBL1221ILC	-
Pilot Light	#HBL1221PL	#HBL3031PL

- Lock Key Type: Same as toggle type except with key operator.

	<u>20 AMP</u>
Single Pole	#HBL1221L
Two Pole	#HBL1222L
Three Way	#HBL1223L
Four Way	#HBL1224L

C. Receptacles:

- Single and duplex convenience receptacles shall be heavy duty specification grade, 2 pole, 3 wire grounding, NEMA 5-20R, rated 20AMP at 125 Volts AC. Receptacles shall have a one-piece all brass wrap around mounting strap with integral ground contacts and ground tension retaining clips, tandem bypass contact, heat resistant thermoplastic rynite base, and high impact nylon face. Receptacles shall be back and side wired, shall have a back wired green ground terminal, automatic ground clip, and threaded brass square head center rivet assembly.

Single Receptacle #HBL5361
 Duplex Receptacle #HBL5362WR

- Ground Fault Duplex convenience receptacles shall be heavy duty specification grade, 2 pole, 3 wire grounding, NEMA 5-20R, rated 20AMP at 125 volts AC. Receptacles shall have a solid brass wrap around mounting strap with pre-tensioned ground contacts, tandem modified bypass contacts, all glass circuit board with conformal coating for superior moisture immunity, 7 noise filtering capacitors, heat resistant thermoplastic base and high impact nylon face. Receptacles shall be back and side wired and shall have a green ground terminal.

Duplex GFCI Receptacle #GFR5362SG

D. Cover Plates:

- Cover plates shall be specification grade non-magnetic Type 302 stainless steel, brushed finish. Where multiple devices are ganged together they shall be mounted

**CITY OF MERIDEN BOARD OF EDUCATION
ROGER SHERMAN ELEMENTARY SCHOOL
FIRST FLOOR NEW AIR CONDITIONING SYSTEM
MERIDEN, CONNECTICUT**

under a common cover plate. Provide switch and receptacle combination plates where switches and receptacles are located together. Cover plates shall be furnished in same Manufacturer as devices.

2. Weatherproof enclosures for outdoor GFCI receptacles shall be cast aluminum, single gang vertical Hubbell #WP26M or single gang horizontal Hubbell #WP26MH. Enclosures shall include gasket and mounting screws, shall have ¼” diameter padlock holes, and shall have large cord openings for use with cover closed.

2.10 FUSES:

- A. Provide current limited, non-renewable fuses, Bussman, Littelfuse, or Gould, UL class J up to 600 Amp and Class L over 600 Amp.
- B. Fuses shall be rated 600V or less A.C., UL listed, and have minimum interrupting rating of 200,000 rms amperes with peak let-through current and maximum clearing values within prescribed UL limits. Fuses for motor feeders or motor circuits shall be Class RK-5 of voltage classification rated for motor with minimum interrupting capacity of 200,000 rms amperes and with minimum time delay of ten seconds at 500%.

2.11 BACKBOARDS:

- A. Backboards shall be constructed of fire retardant plywood sheets, 4' x 8' x ¾".
 1. Paint backboards on all sides with two coats of light gray fire-resistant paint prior to mounting equipment.
 2. Mount backboards on unistrut channel supports.
- B. Provide backboards where indicated on the drawings and for mounting all surface mounted electrical panelboards.

2.12 ACCESS PANELS:

- A. Provide access panels for electrical equipment and wiring splices which are not readily accessible. This includes electrical equipment and wiring splices installed above hung ceilings which are not readily removable, within walls, inside chases, or inside dead cavity spaces.
- B. Access panels shall be prime painted steel, with screwdriver lock, shall bear the same fire rating as the wall or ceiling in which they are installed, and shall be of sufficient size for wiring splice access or electrical equipment removal and replacement. Access panels shall be provided in Milcor manufacture, or approved equal. Provide Milcor Type A in acoustical tile surfaces, Type K for plastered surfaces, and Type M for masonry construction.

**CITY OF MERIDEN BOARD OF EDUCATION
ROGER SHERMAN ELEMENTARY SCHOOL
FIRST FLOOR NEW AIR CONDITIONING SYSTEM
MERIDEN, CONNECTICUT**

2.13 OTHER MATERIALS:

- A. Provide other materials, not specifically described but required for a complete and proper installation, as selected by the contractor subject to the approval of the engineer.

PART 3 - EXECUTION

3.1 GENERAL:

- A. Unless specifically noted or shown otherwise, install all equipment and material specified herein or shown on drawings whether or not specifically itemized herein. PART 3 covers particular installation methods and requirements peculiar to certain items and classes of materials and equipment.
- B. Examine the areas and conditions under which work of this Section will be performed. Correct conditions detrimental to timely and proper completion of the work. Do not proceed until satisfactory conditions are corrected.
- C. The electrical drawings are diagrammatic, but are required to be followed as closely as actual construction and work of other trades will permit. Where deviations are required to conform with actual construction and the work of the other trades, make such deviations without additional cost to the Owner.
- D. Data indicated on the drawings and in these specifications are as exact as could be secured, but their absolute accuracy is not warranted. The exact locations, distances, levels and other conditions will be governed by actual construction and the drawings and specifications should be used only for guidance in such regard.
- E. Verify all measurements at the building. No extra compensation will be allowed because of differences between work shown on the drawings and actual measurements at the site of construction.
- F. Do not scale drawings. Scale indicated on drawings is for establishing reference points only. Actual field conditions shall govern all dimensions.
- G. Coordinate:
 - 1. Coordinate as necessary with other trades to assure proper and adequate provisions in the work of those trades for interface with the work of this Section.
 - 2. Coordinate delivery of electrical equipment to project prior to installation. Equipment stored for an extended period of time prior to installation may be subject to rejection by Architect.
 - 3. Coordinate the installation of electrical items with the schedule for work of other trades to prevent unnecessary delays in the total work.
 - 4. Where electrical items are shown in conflict with locations of structural members and mechanical or other equipment, provide required supports and wiring to clear the encroachment.
 - 5. Prior to roughing, the contractor shall obtain exact fixture and device locations from the Owner. Outlet and fixture locations shown on the drawings are to be used

**CITY OF MERIDEN BOARD OF EDUCATION
ROGER SHERMAN ELEMENTARY SCHOOL
FIRST FLOOR NEW AIR CONDITIONING SYSTEM
MERIDEN, CONNECTICUT**

for general reference only. Roughing of fixtures and outlets shall not proceed until exact locations, heights, and orientations of fixtures and outlets have been agreed upon with the Owner.

6. Arrange installation to provide access to equipment for easy maintenance and repair.

3.2 INSTALLATION OF RACEWAYS AND FITTINGS:

- A. Install wire and cable in approved raceways as specified and as approved by authorities having jurisdiction.
- B. All conduits shall be concealed from view above ceilings, in chases, and in walls. Conduits may only be installed exposed to view in mechanical and electrical rooms and where run overhead in rooms without ceilings
- C. Run conduit and cable parallel to or at right angles with lines of the building, to present a neat appearance.
 1. Make bends with standard conduit elbows or conduit bent to not less than the same radius.
 2. Make bends free from dents and flattening.
- D. Provide code sized conduit unless a larger size is shown on the drawings or specified herein. Minimum size shall be ¾" diameter.
- E. Securely and rigidly support conduit and MC cable throughout the work with approved conduit clips and hangers all in conformance with code seismic requirements.
 1. Do not use mechanics wire for supporting conduit or MC cable.
 2. Do not support conduits on hung ceilings or from mechanical or electrical equipment.
 3. Steel supports and racks shall be galvanized steel channel and fittings, unistrut or approved equal.
 4. Provide clamps and support rods as required.
 5. Steel support rods or support bolts for conduits shall be 1/8 inch diameter for each inch or fraction thereof of diameter of conduit size, but no rod or bolt shall be less than ¼" in diameter.
 6. Horizontal and vertical conduit supports shall not be more than 10' apart or more than 1' from any fitting.
 7. Install conduit and MC cable so it is not in contact with, or resting on, plumbing, fire protection, or HVAC equipment, piping, or ductwork.
- F. Do not install conduit runs exposed on the building exterior.
- G. Maintain at least 3" clearance between conduits and heating pipes when running parallel to these pipes, and at least 1" clearance when running perpendicular to these pipes.
- H. Provide double locknuts on all conduits terminating in sheet metal enclosures. Provide grounding bushings on all feeder conduits.

**CITY OF MERIDEN BOARD OF EDUCATION
ROGER SHERMAN ELEMENTARY SCHOOL
FIRST FLOOR NEW AIR CONDITIONING SYSTEM
MERIDEN, CONNECTICUT**

- I. Provide expansion couplings for rigid metallic and non-metallic conduits where such conduits are subject to thermal expansion and contraction. Provide combination deflection/expansion couplings for metallic and non-metallic conduits where such conduits cross through building expansion joints.
- J. Provide full wall steel flexible conduit for all conduit penetrations through fire walls. Full wall steel flexible conduit shall be 3-hour through penetration fire wall rated.
- K. Install link-seal waterproof seals around all conduit penetrations through basement walls, floors, or foundation walls.
- L. Where conduit is installed underground or is exposed to weather or wet areas make all joints watertight. Seal all site work open conduit ends containing conductors water tight. Cap all site work open conduit ends that do not contain conductors.
- M. Provide necessary sleeves and chases where conduits and cables pass through floors, walls, ceilings, and roofs, and provide other necessary openings and spaces, all arranged for in proper time to prevent unnecessary cutting. Perform cutting and patching in accordance with the provisions for the original work.
- N. Provide offsets prior to entrance into outlet boxes and other electrical equipment for proper adjustment to finished building surfaces. Exercise care when roughing-in conduits which turn up or down to surface mounted panelboards or cabinets, so that conduit extensions to cabinet will be fitted close to wall. Where possible, provide back entry into surface mounted boxes or equipment items.
- O. Install rigid galvanized steel conduit with ends cut square without sharp edges, threaded, and I.D. reamed to remove any burrs. Field made bends shall be of equivalent radius as factory made bends. Exposed threads shall be kept to a minimum.
- P. Seal around all conduit and cable penetrations through fire rated walls and ceilings with 3M Brand CP25N/S fire barrier caulking.
- Q. Carefully clean and dry all conduit before installation of conductors. Do not pull wires into conduit system until building roof and walls are weather-tight and all rough plastering is completed. Provide Prime conduit plugs and end caps to exclude dust, moisture, plaster, or mortar while building is under construction.
- R. Lubricants or cleaning agents which might have deleterious effect on conductor coverings shall not be used for drawing conductors into raceways.
- S. Provide minimum 3/16 inch diameter twisted nylon fish cord in all empty raceways. Provide tag on each end indicating location of other end. Fish cord shall have minimum of 200 pounds tensile strength.
- T. All wiring shall be installed in electrical metallic tubing unless otherwise specified herein or called for on the drawings.
 - 1. Where conduit is installed underground (buried), provide PVC conduit.

**CITY OF MERIDEN BOARD OF EDUCATION
ROGER SHERMAN ELEMENTARY SCHOOL
FIRST FLOOR NEW AIR CONDITIONING SYSTEM
MERIDEN, CONNECTICUT**

2. Where conduit is installed embedded in cinder concrete, provide rigid galvanized steel conduit.
3. Provide intermediate steel conduit for exposed conduit installed below 7 feet in areas such as mechanical rooms, or where subject to physical abuse.
4. Use flexible conduit for final connections to motor driven equipment, recessed light fixtures, transformers, or where subject to vibration. Where such equipment is located in wet areas or exposed to weather use liquid-tight flexible conduit. Flexible connections shall be minimum of 18 inches and maximum of 6 feet long with grounding conductor. Flexible connections shall be used prior to attachment of conduit to equipment housing.

3.3 SLEEVES:

- A. Provide EMT sleeves for each conduit and cable passing through interior walls, partitions, and floors.
 1. Set pipe sleeves in place before wall, floor, or partition is finished.
 2. Support conduit and cable free from sleeves.
 3. Provide sleeves two pipe sizes larger than the conduit or cable passing through, or provide a minimum of ½” clearance.
- B. Provide chrome plated escutcheon plates for each sleeve where exposed to view in finished areas.
- C. Provide GPT Industries WSG galvanized steel wall sleeves for each conduit passing through basement walls or foundation walls. Galvanized steel wall sleeves shall be schedule 40 steel pipe in sizes through 10” diameter and shall have a 0.375” wall thickness for sizes 12” diameter and larger. WSG galvanized steel wall sleeves shall have a 2” collar (water stop) at the mid-point of the sleeve. The 2” collar shall be continuously welded on both sides to the sleeve. Provide GPT Industries Link-Seal modular waterproof seals at all foundation wall sleeves. Where penetrating existing basement or foundation walls provide a core drilled penetration and Link-Seal modular waterproof seal without the galvanized steel wall sleeve.
- D. Caulk the space between sleeve and conduit or cable using 3M Brand OP25N/S fire barrier caulking.
- E. Fireproof all penetrations made in fire rated walls or floors with UL approved materials to prevent passage of fire and smoke and maintain original fire rating of floors or walls.

3.4 CONDUCTOR INSTALLATION:

- A. General:
 1. The interior of all conduits shall be cleared of burrs, moisture, dirt and obstructions before wires are pulled.
 2. Lubricant for pulling wires shall be inert to cable and conduit, shall not in any way restrict ease of pulling through conduit with passage of time, and shall be special lubricant designed specifically for cable pulling and shall be chemically compatible with cable.

**CITY OF MERIDEN BOARD OF EDUCATION
 ROGER SHERMAN ELEMENTARY SCHOOL
 FIRST FLOOR NEW AIR CONDITIONING SYSTEM
 MERIDEN, CONNECTICUT**

B. Color Coding:

1. Consistent phase identification of all conductors shall be maintained as follows:

	<u>120/208V</u>	<u>277/480V</u>
Phase A	Black	Brown
Phase B	Red	Orange
Phase C	Blue	Yellow
Neutral Wire	White	Natural Grey

Provide colored plastic tape of specified color code identification for large size conductors available only in black. Wrap tape three complete turns around conductor, at ends and at connections and splices. Provide same color coding for switch legs as corresponding phase conductor.

C. Minimum Conductor Sizes:

1. The minimum branch circuit conductor size shall be #12AWG. Provide #10AWG conductors for branch circuits where the conductor run exceeds 75 feet, and #8AWG conductors where the conductor run exceeds 150 feet.

- D. Provide the number of conductors required for a given branch circuit, or as required for circuitry, whether indicated on the drawings or not.

E. Neutral Conductors:

1. All branch circuits shall be installed with a separate neutral conductor. Shared neutrals for groups of branch circuits shall not be permitted.

- F. Provide each circuit with a dedicated ground wire back to its respective panel ground bar. Size all ground wires in accordance with NEC requirements. Use #12 minimum size.

- G. MC cable may only be used in dry locations for single phase lighting and receptacle circuits where concealed above hung ceilings or in stud walls. Homeruns shall be conductors in conduit. MC cable shall not be used in masonry partitions, above non-accessible ceilings, for branch circuit homeruns, or where exposed to view.

1. MC cable shall be supported from the building structure using hangers, clips, and approved plenum rated plastic ties. In lay-in ceiling areas the cable shall not rest on ceiling grid or tiles, and shall not be tied to the ceiling grid wire hanging system. Do not use mechanics wire for supporting or securing MC cable.

- H. Identify conductors passing through pull boxes, junction boxes, and wireways to indicate circuit designation. Identify pull boxes and junction boxes as specified herein.

- I. Phase conductors shall be connected to phase supply mains in proper rotation to assure balanced condition on panel. Circuit numbers assigned on drawings are for convenience only. Provide typed circuit directories for all panelboards at conclusion of work, representing circuits as actually connected to panelboard.

**CITY OF MERIDEN BOARD OF EDUCATION
ROGER SHERMAN ELEMENTARY SCHOOL
FIRST FLOOR NEW AIR CONDITIONING SYSTEM
MERIDEN, CONNECTICUT**

- J. Branch circuit wiring and arrangement of home runs have been designed for maximum economy consistent with adequate sizing for voltage drops, circuit ampacities and other considerations.
1. Install the wiring with circuits arranged as shown on the drawings, except as otherwise approved in advance by the Architect and Engineer.
 2. Do not make changes and rearrange circuits without prior approval.
 3. If more than 3 current carrying conductors are installed in one conduit they shall be derated in accordance with the National Electric Code. Do not install more than three 30 Amp single phase or four 20 Amp single phase circuits in the same conduit.
- K. Splices and Connections:
1. Makes splices electrically and mechanically secure with pressure-type connectors.
 - a. For wires size #8AWG and smaller, provide solderless, screw-on connectors, “Scotch-Lock” or equal, 600V rating, of size and type to manufacturer’s recommendation, with temperature ratings equal to the conductor insulation.
 - b. Make splices and terminations to conductors #6AWG and larger with corrosion-resistant, high conductivity, pressure indent, hex screw or bolt clamp connectors, with or without tongues, designed specifically for intended service. Connectors for cables 250 kcmil and larger shall have two clamping elements or compression indents. Terminals for bus connections shall have two bolt holes. Splitbolt connectors, Burndy, IlSCO, or Greaves, shall be acceptable for all splices of conductors #6AWG and larger.
 2. Insulate splices with a minimum of two layers of all weather, heavy duty, abrasion resistant, 8.5 mil thick, 105 degree C. rated vinyl electrical tape where insulation is required. Tape splices 1 ½ times the thickness of the conductor insulation.
 3. Provide high conductivity copper alloy bolt-on lugs with pressure plate and socket set screw or hex head screw to attach wire and cable to disconnect switches, transformers, and other electrical equipment as required.
 4. Provide cable reducing adaptor plugs where required for terminating oversize cable to standard size equipment lugs. Conductor strands shall not be cut in order to fit equipment lugs.
 5. Provide antioxidant joint compound for all conductor connections.

3.5 OUTLET BOXES:

- A. Obtain exact locations of outlets and fixtures from Owner prior to roughing. Make reasonable changes, as defined by Owner in location of outlets and equipment prior to roughing, at no additional cost. Give particular attention to outlets installed in and around casework.
- B. All outlet boxes in finished areas shall be concealed from view above hung ceilings or recessed (flush) in walls and floors. Outlet boxes may only be exposed to view or surface

**CITY OF MERIDEN BOARD OF EDUCATION
ROGER SHERMAN ELEMENTARY SCHOOL
FIRST FLOOR NEW AIR CONDITIONING SYSTEM
MERIDEN, CONNECTICUT**

mount type in mechanical and electrical rooms, for feeding items overhead in rooms without ceilings, and for surface mount devices on existing walls.

- C. Install outlet boxes at uniform heights and straight and true with reference to walls, floors, ceilings and casework.
- D. Provide knockout plugs in boxes with unused openings.
- E. Secure all outlet boxes to building structure with metal straps, rods, or bolts independently of entering conduits or cables.
- F. Provide bar hanger outlets in hollow framed partitions with bar hanger secured to partition studs with self-threading screws, or drill through hangers with Caddy or equal clips.
- G. Provide horizontal separation for outlet boxes mounted on opposite sides of common wall. Back to back or thru-wall boxes will not be permitted.

3.6 PULL BOXES AND JUNCTION BOXES:

- A. Provide pull boxes and junction boxes where shown on the plans and where required to facilitate proper pulling of wires and cables. Install pull boxes no less than one every 100 ft. of straight horizontal conduit run, or three 90 degree bends, unless otherwise noted.

3.7 WIRING DEVICES:

- A. Wherever possible install switches directly adjacent to the strike side of door. Check architectural drawings for door swing.
- B. Device mounting heights indicated below are general. Refer to drawings for special cases. Mounting heights are to centerline of device whether shown on plans or indicated below.

Receptacles	1'-6" AFF	Switches	4'-0" AFF
-------------	-----------	----------	-----------

- C. Install receptacles vertically with grounding posts at top of device, except locate grounding post to left for horizontal mounting.

3.8 WIRING DEVICE PLATES:

- A. Set plates so that all edges are in contact with mounting surface. Provide common device plate for multi-device locations.
- B. Provide electric outlet and switch sealers for all receptacles, switches and technology outlets installed at exterior walls.
- C. Align all wall plate screws with screw slots aligned in the vertical position.

**CITY OF MERIDEN BOARD OF EDUCATION
ROGER SHERMAN ELEMENTARY SCHOOL
FIRST FLOOR NEW AIR CONDITIONING SYSTEM
MERIDEN, CONNECTICUT**

3.9 MOTOR POWER AND CONTROL WIRING:

- A. Contractor shall provide and be responsible for the complete power wiring of all motors and motorized equipment.
- B. Furnish proper overload and short circuit protection for all new motors. Provide a combination thermal overload and disconnect for switch all equipment using fractional horsepower motors.
- C. Check electrical connections and sizing of motor circuit protection and prevent damage to motor and equipment from incorrect direction of rotation.
- D. Provide mounting for motor and equipment disconnect switches adjacent to motor and supported independent of motor.
- E. Motor starters and disconnects, where grouped, shall be mounted on $\frac{3}{4}$ " thick fire retardant plywood mounting boards painted with light gray fire resistant paint.
- F. Provide interlock wiring where required for motors and controllers, whether shown on the drawings or not.
- G. Connections to miscellaneous building equipment:
 - 1. Wire to and connect to, all items of building equipment not specifically described in this Section but to which electrical power is required.
 - 2. Coordinate as necessary with other trades and suppliers to verify types, numbers and locations of equipment.

3.10 GROUNDING SYSTEM:

- A. Provide a complete grounding system which will thoroughly ground the non-current carrying metal parts of every piece of installed equipment, as described herein and as indicated on the drawings.
- B. System shall be mechanically and electrically connected to provide an independent return path to the grounding sources.
- C. Each grounding conductor shall have a minimum capacity of 25 percent of the rated capacity of the equipment it grounds, unless otherwise indicated.
- D. The minimum size of grounding conductors shall be No. 12 AWG copper. Insulation color of grounding conductors shall be green.
- E. Provide insulated throat grounding bushings at all feeder conduit connections to switchboards, panelboards, disconnect switches, wireways, and pull boxes. Connect grounding bushings within each enclosure, backbox, wireway, or pull box by #4 AWG bare copper bonding conductor connected to a grounding lug welded to the enclosure, backbox, wireway, or pull box.
- F. Provide a separate green ground conductor for each feeder and branch circuit.

**CITY OF MERIDEN BOARD OF EDUCATION
ROGER SHERMAN ELEMENTARY SCHOOL
FIRST FLOOR NEW AIR CONDITIONING SYSTEM
MERIDEN, CONNECTICUT**

- G. Grounding of Motors: Motors shall be grounded by connecting a green covered conductor from a grounding bushing in the starter to the motor frame. Conductor shall be installed in the conduit with the circuit conductors and terminated in the motor connection box, providing the terminal is mechanically connected to the frame. If this is not feasible, grounding conductor from the starter shall be extended through an insulated bushed opening in the connection box and connected to motor base.
- H. Tests: Entire system shall be thoroughly tested on completion for ground continuity and capacity. Provide not more than 10 ohms resistance between main ground system and equipment frame system neutral and/or derived neutral point.

3.11 SPECIAL REQUIREMENTS:

- A. Wiring shall be bundle tied where passing through pull boxes, wireways, and panelboards in neat and orderly manner with plastic cable ties. Cable ties shall be Ty-Raps as manufactured by Thomas & Betts, or equal.
- B. Turn branch circuits and auxiliary system wiring out of wiring gutters at 90 degrees to circuit breakers and terminal lugs.
- C. Provide two spare 1 1/2 inch conduits for flush panels. Conduits shall extend from top of each panel to one foot above hung ceilings, turn out from wall toward panel access side and terminate with nylon bushing.
- D. Provide miscellaneous hardware and support accessories, including support rods, nuts, bolts, screws, and other such items, with galvanized or cadmium plated finish, or other approved rust inhibiting coatings.
- E. Unload electrical equipment and materials delivered to site. Pay cost for rigging, hoisting, lowering and moving electrical equipment on site, in building or on roof. During construction provide additional protection against moisture, dust accumulation and physical damage of electrical equipment. Provide temporary heaters within units, as approved to evaporate excessive moisture and provide ventilation as required.

3.12 TESTING AND INSPECTION:

- A. Provide personnel and equipment, make required tests, and secure required approvals from the Architect and governmental agencies having jurisdiction.
- B. When material and/or workmanship is found to not comply with the specified requirements, within three days after receipt of notice of such non-compliance remove the non-complying items from the job site and replace them with items complying with the specified requirements, all at no additional cost to the Owner.
- C. Perform all required adjustments and settings. Verify and correct deficiencies as necessary including voltages, tap settings, trip settings and phasing of equipment from distribution system to point of use.
- D. Provide all necessary testing equipment.

**CITY OF MERIDEN BOARD OF EDUCATION
ROGER SHERMAN ELEMENTARY SCHOOL
FIRST FLOOR NEW AIR CONDITIONING SYSTEM
MERIDEN, CONNECTICUT**

- E. Test wiring, buswork, and connections for continuity and ground by “megger” test. Minimum insulation resistance between conductors and ground shall be as follows:
1. For circuits of #14 or #12 AWG wire: 1,000,000 ohms.
 2. Conductor current carrying capacities from 25 to 50 amperes, inclusive: 250,000 ohms.
 3. Conductor current carrying capacities from 51 to 100 amperes, inclusive: 100,000 ohms.
 4. Conductor current carrying capacities from 101 to 200 amperes, inclusive: 50,000 ohms.
 5. Conductor current carrying capacities from 201 to 400 amperes, inclusive: 25,000 ohms.
 6. Conductor current carrying capacities from 401 to 800 amperes, inclusive: 12,000 ohms.
 7. Conductor current carrying capacities over 800 amperes: 5,000 ohms.
- F. Main ground electrode system shall not exceed 10 ohms unless specified otherwise.
1. Verify ground resistance by ground continuity test between main ground system and equipment frame system neutral and/or derived neutral point.
 2. Perform ground continuity test by passing minimum of ten Amps DC between ground reference system and ground point. Calculate resistance by voltage drop method.
- G. In the Owner’s Presence:
1. Test all parts of the electrical system and prove that all such items provided under this Section function electrically in the required manner.
- H. Balance all panels as follows:
1. Turn on all lighting and equipment served by a panel and measure the current in each branch circuit phase and neutral conductor and in each phase and neutral bus-bar. Log all measurements taken and then correct imbalance by substituting branch circuits from phase to phase until optimum balance is achieved. Log all final current measurements and submit for the Engineer’s review.
 2. Also measure and log voltages between each phase bus-bar and between each phase bus-bar and neutral bus-bar and submit measurements for the Engineer’s review.

3.13 PROJECT COMPLETION:

- A. Upon completion of the work of this Section, thoroughly clean all exposed portions of the electrical installation, removing all traces of soil, labels, grease, oil and other foreign material, and using only the type cleaner recommended by the manufacturer of the item being cleaned.

**CITY OF MERIDEN BOARD OF EDUCATION
ROGER SHERMAN ELEMENTARY SCHOOL
FIRST FLOOR NEW AIR CONDITIONING SYSTEM
MERIDEN, CONNECTICUT**

- B. Vacuum all exteriors and interiors of switchboards, panelboards, safety switches, and equipment racks to remove all dust, dirt, cable clippings, etc.
- C. Equipment with damage to painted finish shall be repaired to satisfaction of the Owner.
- D. On the first day the facility is in operation, for at least eight hours, at a time directed by the Owner, provide a qualified foreman and crew to perform such electrical work as may be required by the Owner.
- E. Thoroughly indoctrinate the Owner's operation and maintenance personnel in the contents of the operations and maintenance manual required to be submitted under these Specifications.

3.14 EQUIPMENT SPECIFIED:

- A. Contractor shall furnish equipment or systems in manufacturers specified or named herein or on the drawings. No other manufacturers shall be considered.

END OF SECTION 26 05 00

LIST OF DRAWINGS

COVER

M1.1 1st.FLOOR MECHANICAL PART PLANS

M1.2 MECHANICAL SCHEDULES, DETAILS AND PIPING DIAGRAMS

E1.0 BASEMENT PART PLAN, SCHEDULES, RISER AND DETAILS

E1.1 1st FLOOR POWER PART PLAN



ROGER SHERMAN ELEMENTARY SCHOOL



FIRST FLOOR NEW AIR CONDITIONING SYSTEM

64 N PEARL STREET
MERIDEN, CONNECTICUT 06450

M/E/P ENGINEER
BEMIS ASSOCIATES LLC
185 MAIN STREET
FARMINGTON, CONNECTICUT
Phone: 860-667-3233
Fax: 860-321-7070

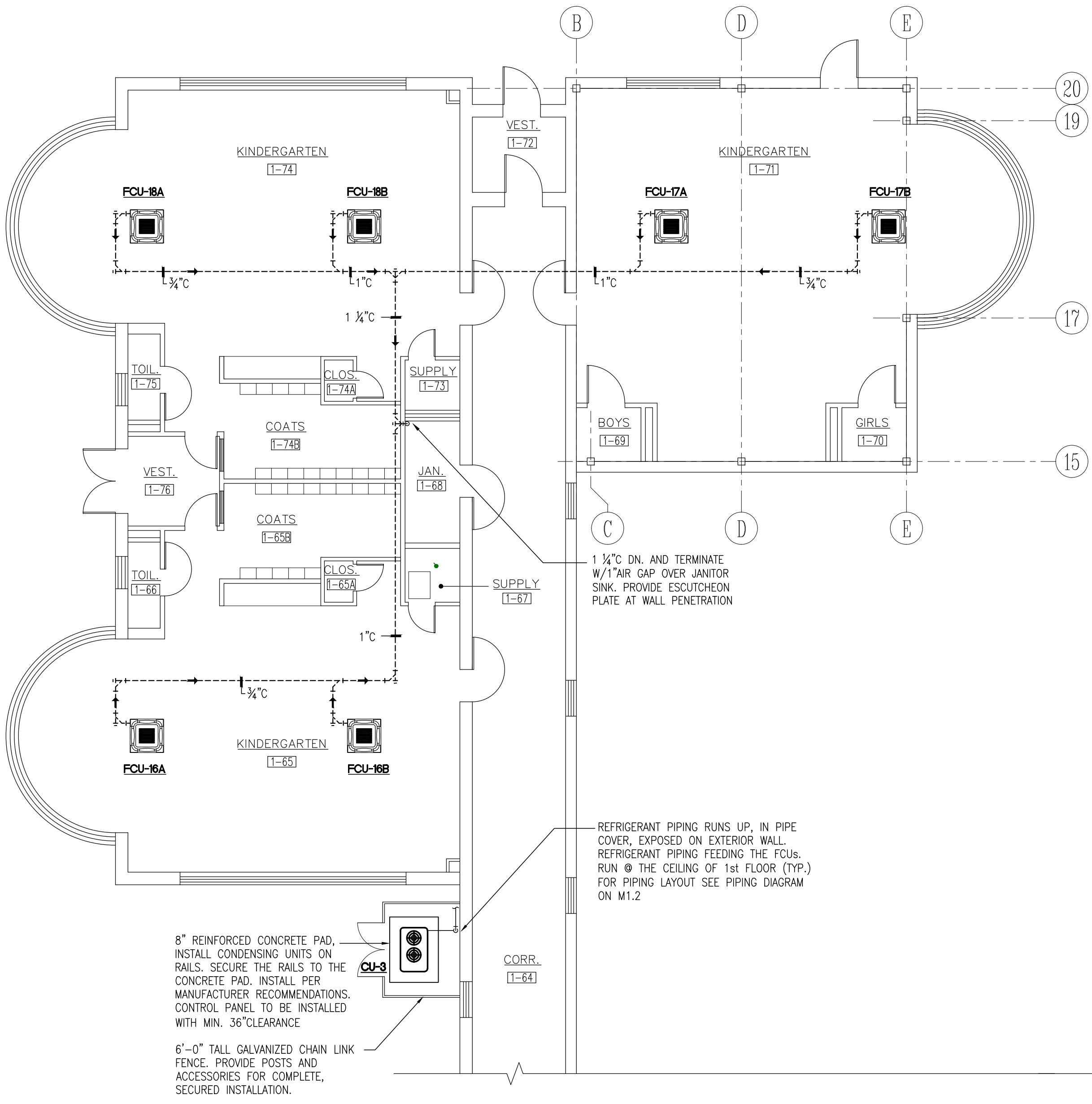

NORTHWEST FIRST FLOOR PART PLAN - MECHANICAL
SCALE 1/8"=1'-0"

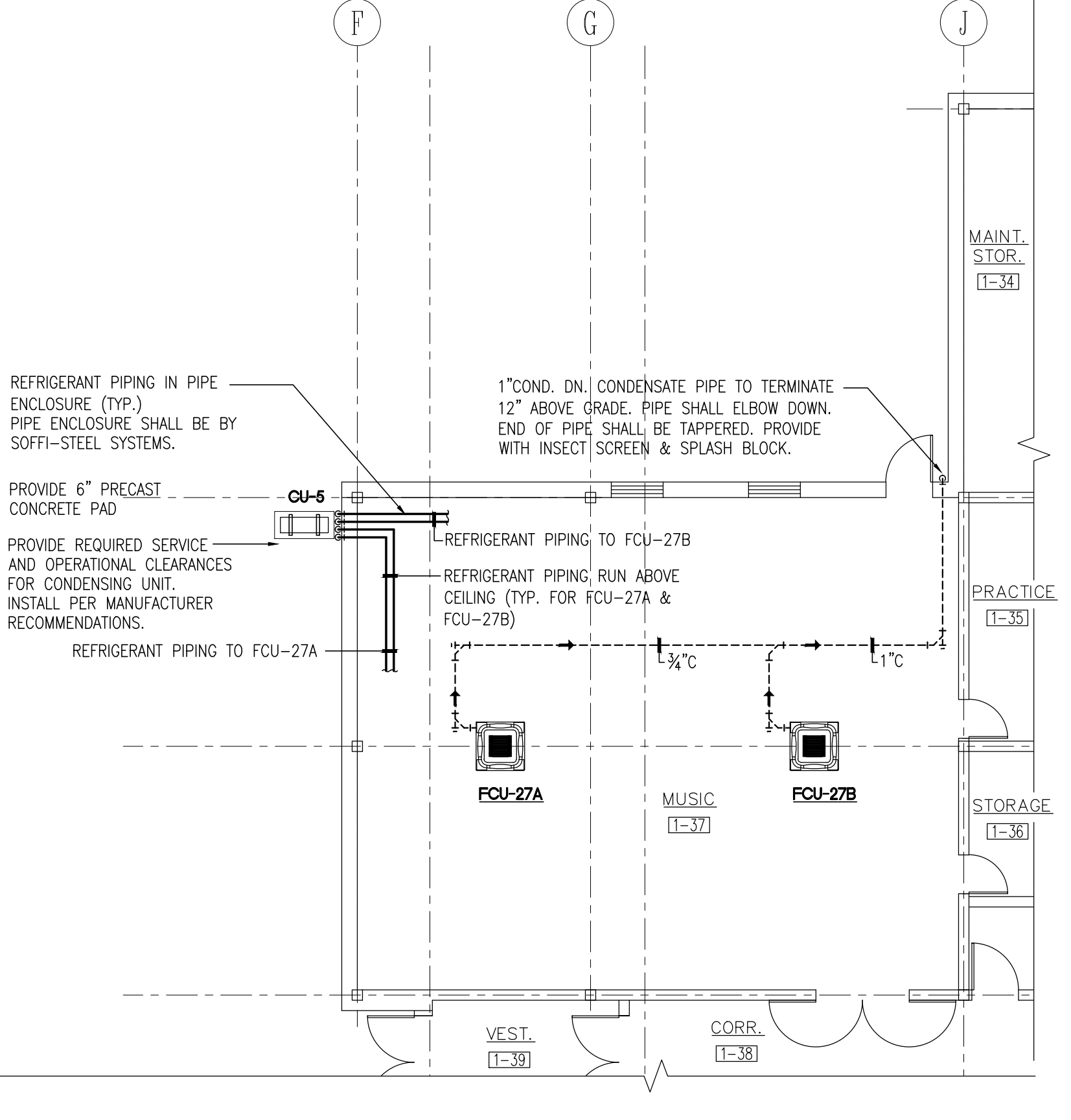

- MECHANICAL GENERAL NOTES**
- INSTALL UNITS WITH CLEARANCE FOR SERVICE.
 - REFRIGERANT PIPING SHALL BE DEOXYGENATED PHOSPHOROUS SEAMLESS COPPER PIPE OR EQUIVALENT.
 - BOTH GAS AND LIQUID PIPING MUST BE INSULATED WITH GLASS FIBER OR HEAT RESISTANCE POLYETHYLENE FOAM, 3/8 INCH OR MORE, MIN. 255°F HEAT RESISTANCE FOR THE GAS PIPE AND MIN. 160°F HEAT RESISTANCE FOR THE LIQUID PIPE.
 - BRANCH PIPES SHALL BE INSULATED IN ACCORDANCE WITH THE INSTRUCTIONS OF THE MANUFACTURER.
 - THE LIQUID PIPE AND GAS PIPE SHALL HAVE THE SAME LENGTH AND BE LAID IN THE SAME ROUTE.
 - THE CONDENSATE PIPE CANNOT BE TIED WITH THE REFRIGERANT PIPE.
 - EXPANSION JOINT SHALL BE ADDED EVERY 40 FT OF STRAIGHT PIPING RUN.
 - DRAWINGS ARE DIAGRAMMATIC AND SHOW GENERAL INTENT OF WORK, NOT EXACT EQUIPMENT LOCATION. CONTRACTOR SHALL COORDINATE WITH OTHER TRADES BEFORE WORK BEGINS.
 - THERE SHALL BE NO EXPOSED PIPING. PIPES SHALL RUN CONCEALED ABOVE CEILING OR IN WALLS. WHERE NOT POSSIBLE, THE CONTRACTOR SHALL PROVIDE PIPE CHASES. ON EXTERIOR WALLS, PIPES SHALL RUN ON WARM SIDE OF THE INSULATION AND HAVE 2" INSULATION.
 - CONTRACTOR SHALL PROVIDE REFRIGERANT PIPING LAYOUT WITH PIPE SIZES FOR ALL THE REFRIGERANT SYSTEMS, CONFIRMED BY THE MANUFACTURER PRIOR TO INSTALLATION.

- CONDENSING DRAIN - GENERAL NOTES**
- DRAWINGS ARE DIAGRAMMATIC AND SHOW GENERAL INTENT OF WORK, NOT EXACT EQUIPMENT LOCATIONS. CONTRACTOR MUST COORDINATE EQUIPMENT LOCATION BEFORE PROCEEDING WITH ANY WORK.
 - ALL CONDENSING DRAIN SHALL HAVE A PITCH OF 1/8" PER FT UNLESS NOTED OTHERWISE.
 - CONDENSATE PIPING SHALL BE COPPER. PIPE SHALL BE INSULATED.
 - THERE SHALL BE NO EXPOSED PIPING. PIPES SHALL RUN CONCEALED ABOVE CEILING. WHERE NOT POSSIBLE, THE CONTRACTOR SHALL PROVIDE PIPE CHASES.
 - A VISIT TO THE SITE AND EXAMINATION OF THE OTHER MECHANICAL TRADES SHOWING ALL DETAILS OF CONSTRUCTION IS A REQUIREMENT BEFORE SUBMITTING A PROPOSAL.
 - THE CONTRACTOR SHALL VISIT THE JOB SITE TO VERIFY ALL DIMENSIONS AND JOB CONDITIONS.
 - THE DRAWINGS ARE DIAGRAMMATIC IN NATURE AND ALL OFFSETS, FITTINGS, TRANSITIONS, CLEANOUTS, VALVES AND ACCESSORIES ARE NOT NECESSARILY SHOWN.
 - IT IS THE INTENT THAT ALL WORK SHALL BE COMPLETE IN EVERY RESPECT AND THAT THE MATERIAL OR WORK SPECIFICALLY NOT INDICATED ON THE DRAWINGS, BUT NECESSARY TO COMPLETE THE WORK, SHALL BE PROVIDED.

- MECHANICAL - CONTROL - GENERAL NOTES**
- ALL ELECTRIC WIRING, CONNECTIONS, DEVICES, RACEWAY AND HARDWARE REQUIRED FOR THE INSTALLATION OF THE TEMPERATURE CONTROL SYSTEM AS SPECIFIED AND SHOWN ON THE DRAWINGS SHALL BE PROVIDED BY THE TEMPERATURE CONTROLS CONTRACTOR (TCC).
 - ALL CONTROL WIRING SHALL BE INSTALLED IN ACCORDANCE WITH THE CONTROL SYSTEM MANUFACTURER'S REQUIREMENTS AND CURRENT CODE.
 - ALL LOW VOLTAGE CONTROL WIRING SHALL BE PLENUM RATED CABLE OF TYPES AND SIZES REQUIRED BY THE CONTROL SYSTEM MANUFACTURER.
 - PROVIDE MINIMUM OF 3/4" EMT CONDUIT FOR ALL WIRING EXPOSED TO VIEW AND FOR WIRING DROPS AND RUNS WITHIN NEW WALLS. ALL CONDUITS SHALL TERMINATE WITH JUNCTION BOXES OR OUTLET BOXES. PROVIDE BUSHINGS FOR ALL WIRING ENTERIES INTO THE CONDUIT SYSTEM.
 - ALL TEMPERATURE CONTROL WIRING SHALL BE NEATLY INSTALLED WITH CABLE RUNS INSTALLED PARALLEL TO OR AT RIGHT ANGLES TO THE LINES OF THE BUILDING. ALL WIRING IN NORMALLY OCCUPIED AREAS OF THE BUILDING SHALL BE CONCEALED FROM VIEW. OPEN CABLE RUNS ABOVE CEILINGS SHALL BE BUNDLE TIED WITH PLASTIC CABLE TIES AND SHALL BE SUPPORTED FREE FROM THE CEILING AND MECHANICAL/ELECTRICAL EQUIPMENT USING APPROVED CABLE HANGERS AND CABLE CLIPS.
 - THE TEMPERATURE CONTROL CONTRACTOR SHALL COORDINATE POWER SUPPLY REQUIREMENTS OF THE CONTROL SYSTEM WITH DIVISION 26.
 - REFER TO SPECIFICATION FOR ADDITIONAL CONTROLS REQUIREMENTS AND THE EQUIPMENT SEQUENCE OF OPERATIONS.
 - ALL CONTROLS DEVICES AND ELECTRONICS SHALL BE INSTALLED WITHIN A NEMA-1 ENCLOSURE LOCATED WITHIN PROXIMITY TO THE EQUIPMENT SERVED.
 - REFER TO MECHANICAL SPECIFICATIONS FOR SEQUENCE OF OPERATIONS AND ADDITIONAL DDC SENSOR REQUIREMENTS.

- NEW WORK DRAWING KEYED NOTES**
- CONNECT REFRIGERANT PIPING PER MANUFACTURER RECOMMENDATIONS, REFER TO DRAWING M1.2 (VARIABLE REFRIGERANT VOLUME SYSTEM PIPING DIAGRAM) FOR PIPES SIZING. PROVIDE 1" TRAPPED CONDENSATE PIPING, INSTALL PIPING PER MANUFACTURER RECOMMENDATIONS. SEAL AIR AND WATER TIGHT ALL PIPING PENETRATIONS.
 - PROVIDE SECONDARY DRAIN PAN WITH OVERFLOW SWITCH TO SHUT DOWN UNIT.
 - PROVIDE TRAPPED CONDENSING DRAIN, PIPE TO JANITOR SINK, REFER TO TYPICAL DETAIL.

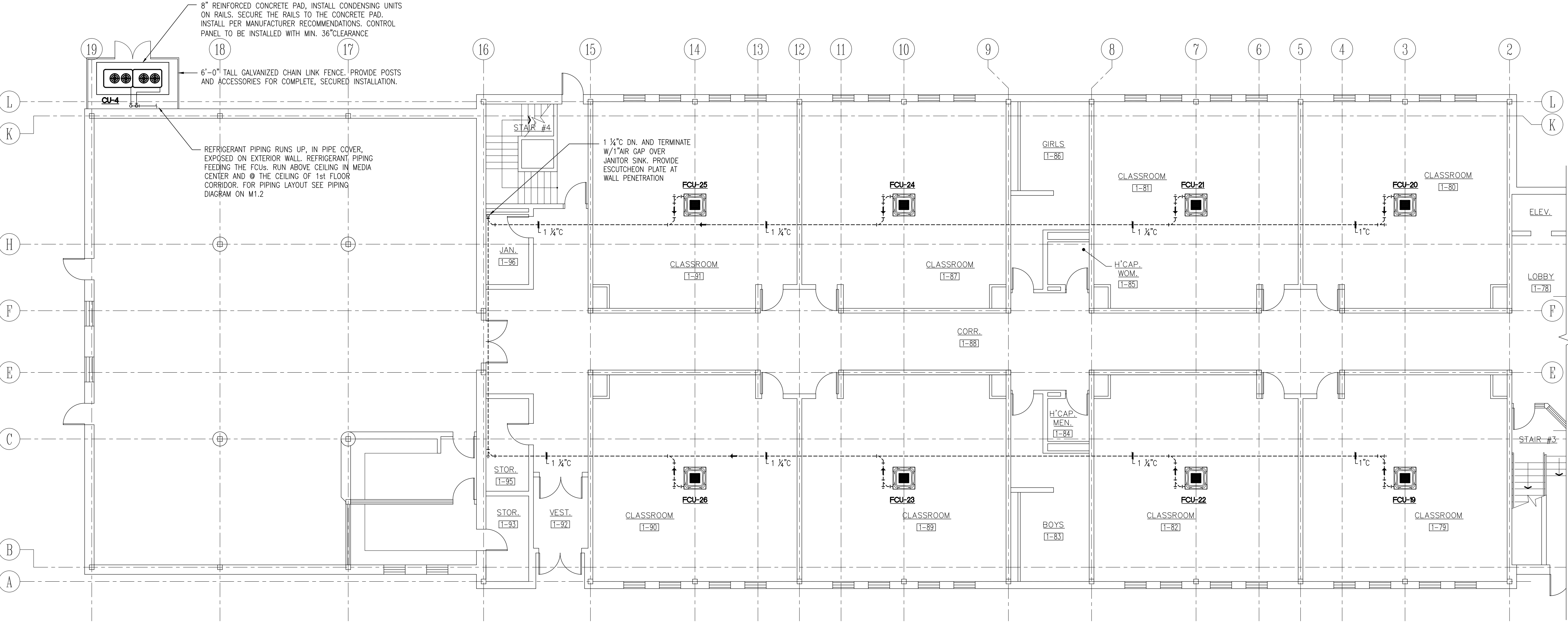

SOUTHWEST FIRST FLOOR PART PLAN - MECHANICAL
SCALE 1/8"=1'-0"

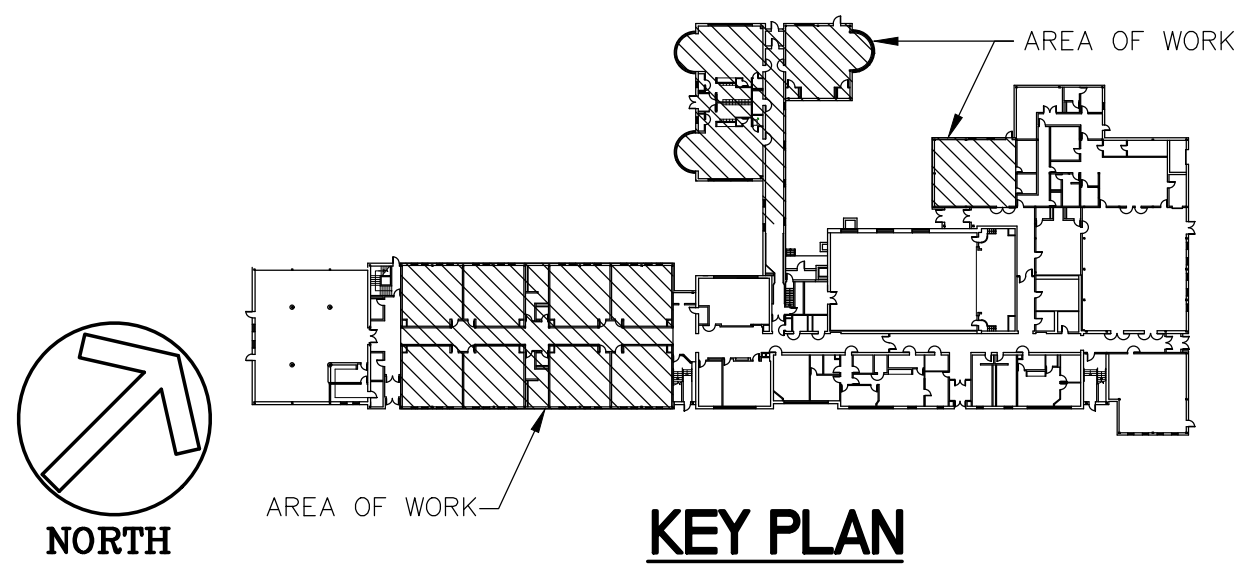

VARIABLE REFRIGERANT VOLUME - AIR-COOLED CONDENSING UNIT SCHEDULE (DAIKIN BASIS OF DESIGN)

TAG: ROOM	BASIS OF DESIGN (DAIKIN)	DESCRIPTION	COOLING CAPACITY	HEATING CAPACITY	REFRIGERANT CHARGE	CONNECTION RATIO (%)	ELECTRICAL											DIMENSIONS	EFFICIENCY (NonDucted)	Options and Accessories	NOTES													
							BTU/h	AMBIENT DESIGN (°F DB)	BTU/h	AMBIENT DESIGN (°F DB / WB)	Factory Charge (lbs)	Add'l Refrigerant (lbs)	MIN CIRCUIT AMPS (MCA)			MAX OVERCURRENT PROTECTION (MOP)						RUNNING CURRENT (RLA)		WxHxD (inch)	WEIGHT (lbs)	EER	EER2	IEER	COP47	COP17	SEER	HSPF2		
													mod #1	mod #2	total	mod #1	mod #2					total	mod #1										mod #2	total
CU 1 (Existing)	RXYQ_XATJA	Air cooled heat pump (2)	195,522	95.0	286,014	47.0 / 43.0	41.0	37.8	90.9	208V-230V 3ph	55.1	36.3	91.4	60.0	45.0	105.0	33.4	26.2	59.6	48.9 x 66.7 x 30.2 / 48.9 x 66.7 x 30.2	694.5 / 526.9	10.8	-	20.3	-	-	-	-	-	-	-	-	-	Reference Only
CU 2 (Existing)	RXYQ_XATJA	Air cooled heat pump (2)	215,458	95.0	313,369	47.0 / 43.0	36.2	52.5	100.0	208V-230V 3ph	55.1	55.1	110.2	60.0	60.0	120.0	33.4	66.8	48.9 x 66.7 x 30.2 / 48.9 x 66.7 x 30.2	694.5 / 694.5	10.5	-	20.1	-	-	-	-	-	-	-	-	-	Reference Only	
CU 3	RXYQ_AATAA	Air cooled heat pump (1)	118,492	95.0	159,012	47.0 / 43.0	25.8	13.9*	100.0	208V-230V 3ph	47.8	-	47.8	50.0	-	50.0	25.8	-	25.8	48.8 x 65.4 x 30.1	749.6	12.4	-	25.4	3.7	2.18	-	-	-	-	-	VRV6-SHL-FR (1), VRV6-SHL-T (1), VRV6-SHL-R (1)		
CU 4	RXYQ_AATAA	Air cooled heat pump (2)	229,295	95.0	310,472	47.0 / 43.0	51.6	41.9*	100.0	208V-230V 3ph	47.8	47.8	95.6	50.0	50.0	100.0	25.8	25.8	51.6	48.8 x 65.4 x 30.1 / 48.8 x 65.4 x 30.1	749.6 / 749.6	11.4	-	22.4	3.5	2.41	-	-	-	-	-	BHPF22P100U (1), VRV6-SHL-FR (2), VRV6-SHL-T (2), VRV6-SHL-R (1)		
CU-5	RXTQ_TBVIJUA	Air cooled heat pump (1)	42,540	95.0	51,346	47.0 / 43.0	7.5	2.6*	100.0	208-230V 1ph	29.1	-	29.1	35.0	-	35.0	19.0	-	19.0	37.0 x 39.0 x 12.6	176.4	-	-	-	-	-	-	18.6	8.5	-	KPW5G12 (1)			

Schedule Notes:
 Manufacturer must be certified, listed, and labeled per AHRI 1230.
 System rating data based on design ambient conditions for cooling and for heating.
 Submitted performance data must be fully de-rated for all components and accessories, including but not limited to, line length, vertical separation, connection ratio, design conditions, condenser coil coating.
 Condensing units must have fully modulating INVERTER compressors.
 Condensing units must have auto changeover functions.
 Condensing units must have snow hoods on the top and all four sides.
 Demand limiting relay contact must be provided.
 EEV actuators must be removable from valve body without disturbing the refrigerant system.
 FCU thermostats must provide +/- 1 degree dead-band set-point and control capability.
 Systems shall be provided with i-Touch Manager controller with BACNet based software for displaying up to 8 DIII-Net systems with 128 indoor units per system.PC by others.
 Manufacturer submittal must include refrigerant piping diagram with pipe diameters, lengths, and refrigerant volume.
 Substitute manufacturer shall be responsible for additional piping and refrigerant.

Substitute manufacturer that use electric panel or base pan heaters shall not be acceptable.
 Contractor to verify piping dimensions.
 Installing contractor must have successfully completed manufacturers certified installation class within past 36 months.

Contractor to furnish and install insulation on refrigerant piping.
 Manufacturers Representative must have local stock of parts and factory certified technician on staff.
 Manufacturers Representative shall provide proof of ongoing installation training at their local facility for at least the past 5 years.
 Manufacturers Representative shall provide proof of continuous sales and support of their products for at least 15 years.
 Mechanical contractor shall be responsible for all direct costs and operating costs increases for 20 years associated with any deviations resulting from changes in design.
 3-phase Air cooled condensing units must have published performance data with 200% indoor connected capacity.
 Condensing units must be furnished with protective coil coating to withstand ASTM B117 salt spray test for a minimum of 1000 hours.Performance of system must be de-rated for coil coating.
 Manufacturer must certify and submit system performance at extreme conditions of 122 degrees FDB ambient in cooling mode and -22 degrees FWB in heating mode.
 Manufacturer must provide 10 years parts warranty on all Condensing Units. Warranty conditions must be clarified during submittal phase.

NOTES:
 1. UNIT MANUFACTURER SHALL PROVIDE WIRED CONTROLLER INDOOR UNIT.
 2. PROVIDE REFRIGERATION LINE SETS FOR AIR CONDITIONING UNIT WITH CONNECTIONS TO CONDENSING UNIT.
 3. POWER WIRING AND RACEWAY BY DIVISION 26.
 4. DISCONNECTS AND STARTING RELAYS FURNISHED BY DIVISION 23.
 5. REFER TO DIVISION 23 SPECIFICATION FOR ADDITIONAL REQUIREMENTS.
 6. UNITS USING CFC BASED REFRIGERANTS WILL NOT BE ACCEPTABLE.
 7. CASSETTE UNITS SHALL HAVE MULTIFUNCTION CASSEMENT/NERV 10 FILTER
 8. OUTDOOR UNITS SHALL HAVE WIND Baffle
 9. SYSTEM SHALL BE BACKUP READY. COORDINATE WITH TEMPORARY CONTROL CONTRACTOR

MECHANICAL - GENERAL NOTES:
 1. INSTALL UNITS WITH CLEARANCE FOR SERVICE.
 2. DRAWINGS ARE DIAGRAMMATIC AND SHOW GENERAL INTENT OF WORK, NOT EXACT EQUIPMENT LOCATION.
 3. THE LOCATION OF ALL AC CASSETTE UNITS SHALL BE COORDINATED WITH THE EXISTING CEILING.
 4. CONTRACTOR SHALL PROVIDE REFRIGERANT PIPING, INSULATE ALL REFRIGERANT PIPES.
 5. CONDENSATE PIPING SHALL BE COPPER, PIPE SHALL BE INSULATED.
 6. PROVIDE PIPE COVER TO NEW PIPES TO AC UNITS. CONTRACTOR TO FIELD VERIFY PIPE COVER DIMENSIONS.
 7. PIPE INSULATION SHALL RUN CONTINUOUSLY THROUGH WALLS/PARTITION. THIS CONTRACTOR SHALL OPEN WALLS AS NECESSARY. SEAL PENETRATIONS

VARIABLE REFRIGERANT VOLUME - INDOOR UNIT SCHEDULE (DAIKIN BASIS OF DESIGN)

TAG	ROOM	BASIS OF DESIGN (DAIKIN)	TYPE	CONNECTED TO:		SUPPLY FAN AIR FLOW RATE cfm	COOLING CAPACITY		HEATING CAPACITY		ELECTRICAL			DIMENSIONS WxHxD inch	WEIGHT lbs	Options and Accessories	NOTES	
				CONDENSING UNIT	ZONE CHANGE/COVER DEVICE		TOTAL BTU/h	SENSIBLE BTU/h	TOTAL ENTERING AIR °F DB	ENTERING AIR °F WB	TOTAL ENTERING AIR °Fdb	POWER SUPPLY Voltage - Phase	Min Circuit Amps MCA					Max Overcurrent Protection MOP
				FCU 16B	[1-65] Kindergarten		FXFQ-TVJU	Round Flow Sensing Cassette	CU 3	No	777	20,642	16,860					75.0

Schedule Notes:
 360 degree air flow distribution and three room sensors enables optimized occupant comfort and efficiency
 Built-in condensate pump
 Individually controlled supply air louvers for comfortable air supply
 Unit to be optimizable with up to 18 possible air flow patterns
 Standard Limited Warranty: 10-year warranty on all parts

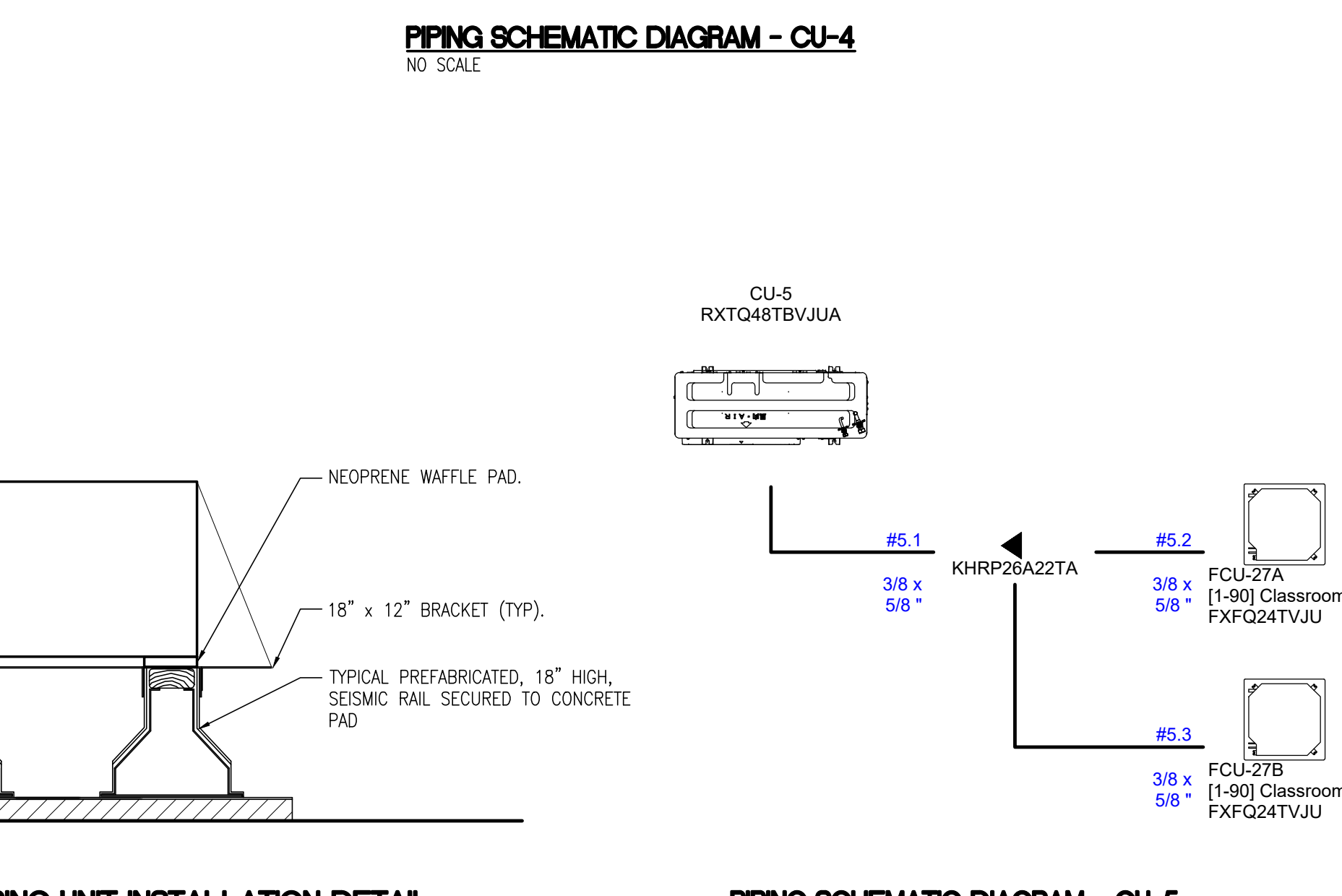
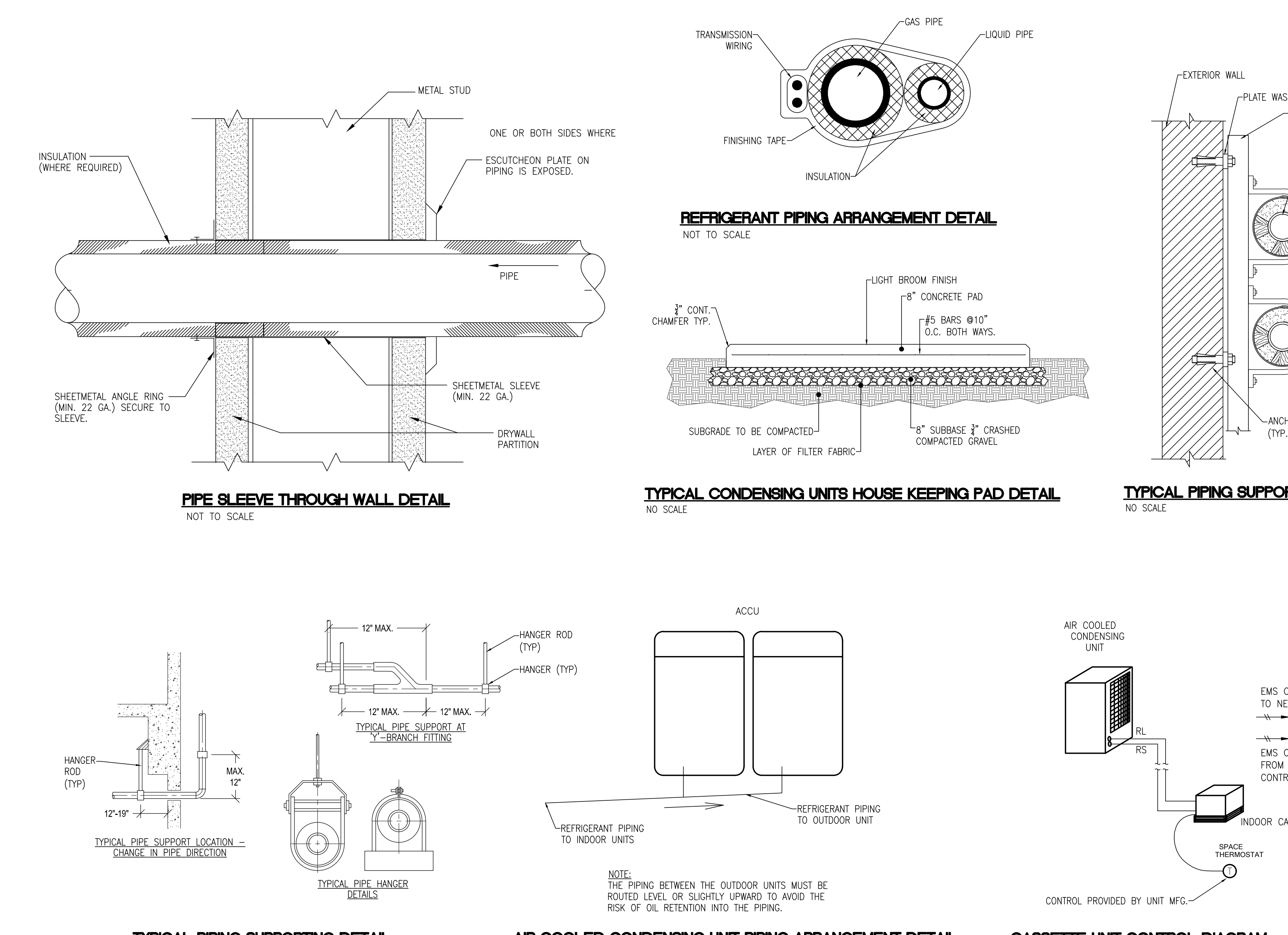
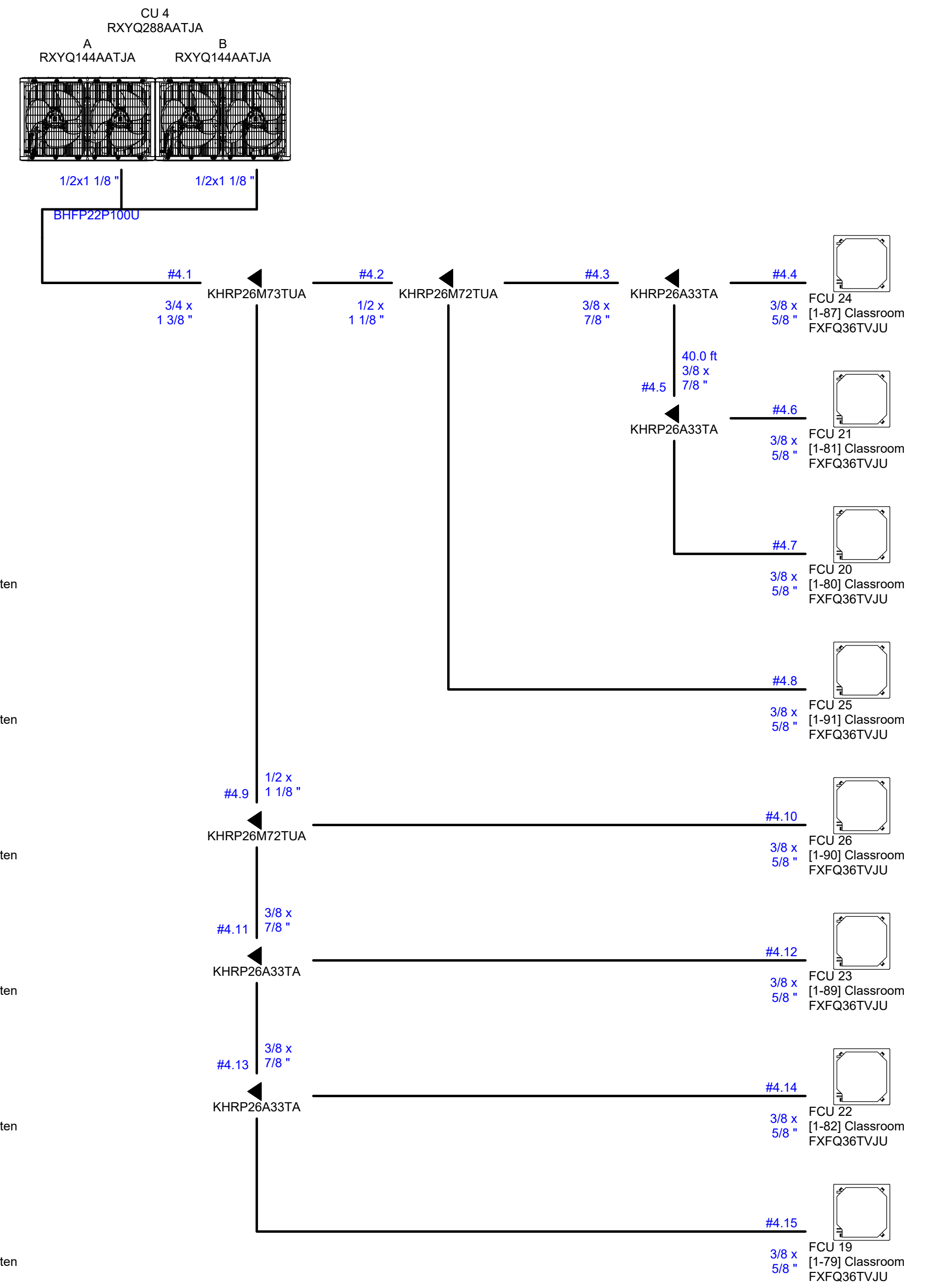

REVISIONS

COPYRIGHT
 This drawing is an instrument of service and shall remain the property of BEIMS ASSOCIATES, L.L.C. No part of this drawing may be reproduced or transmitted in any form or by any means, electronic, mechanical, photocopying, recording, or by any information storage and retrieval system, without the express written approval of BEIMS ASSOCIATES, L.L.C.

Minimum number of revisions shall be shown to meet the requirements of the project. Revisions shall be numbered and dated in descending order of the revision number in the right margin of this drawing. A revision number shall be placed in the right margin of this drawing. A revision number shall be placed in the right margin of this drawing. A revision number shall be placed in the right margin of this drawing.

PANEL: ACP1		MANUFACTURER & MODEL # EATON (CUTLER HAMMER) #POW-R-LINE 3a										
MOUNTING: SURFACE		VOLTAGE CLASSIFICATION: 208Y/120V, 3 PHASE, 4 WIRE										
MAINS: 400 A MCB		SCR (FULLY RATED): 100K A.I.C.										
200% NO		SPD: NO										
BREAKER		PHASE LOAD KW						BREAKER				
#	TRIP RATING	POLE	LOAD DESCRIPTION	LOAD KW	A	B	C	LOAD KW	LOAD DESCRIPTION	POLE	TRIP RATING	#
1				6.61	6.61	13.22		13.22				2
3	60	3	CU-3	6.61			6.61	13.22	CU-4	3	125	4
5				6.61			6.61	13.22				6
7	15	2	Southwest FCU's	1.20	1.20	1.20		1.20	Northwest FCU's	2	15	8
9				1.20			1.20	1.20				10
11	20	1	Exterior Duplex Rec	0.36			0.36	3.03	CU-5	2	35	12
13				0.10	0.10	3.03		3.03				14
15	15	2	FCU 27 & 28	0.10			0.10	0.00				16
17				0.10				0.00				18
19				0.00	0.00			0.00				20
21				0.00			0.00	0.00				22
23				0.00				0.00	0.00			24
25				0.00	0.00			0.00	0.00			26
27							0.00	0.00				28
29							0.00	0.00				30
TOTAL LOAD:				25.36	22.34	23.22	TOTAL LOAD ON PANEL		71	197		
										KW		
										AMPS		

- NOTES:
- PROVIDE WITH SILVER PLATED COPPER BUS BARS AND COPPER GROUND BAR.
 - PROVIDE WITH DOOR-IN DOOR TRIM.
 - PROVIDE WITH BLACK FACE, WHITE CORE ENGRAVED NAMEPLATE FIXED TO PANEL WITH TWO SCREWS OR RIVETS.
 - PROVIDE WITH METAL FRAME PLASTIC COVER CIRCUIT DIRECTORY FRAME.
 - PROVIDE WITH TYPE WRITTEN CIRCUIT DIRECTORY REPRESENTING CIRCUITS AS ACTUALLY CONNECTED TO PANEL.
 - CIRCUIT BREAKERS SHALL BE BOLT-ON TYPE.
 - * = GFCI C/B.
 - = AFCI C/B.

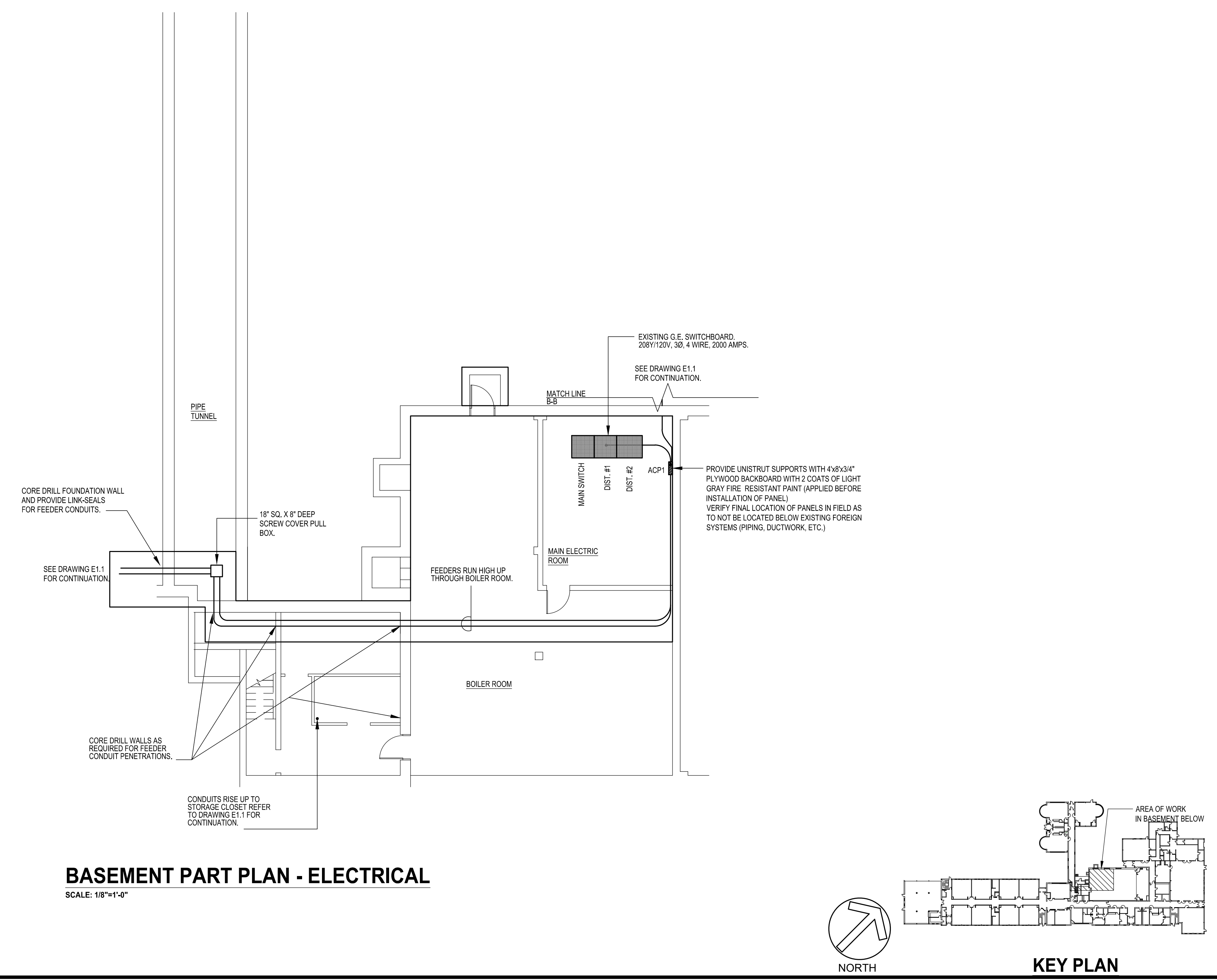
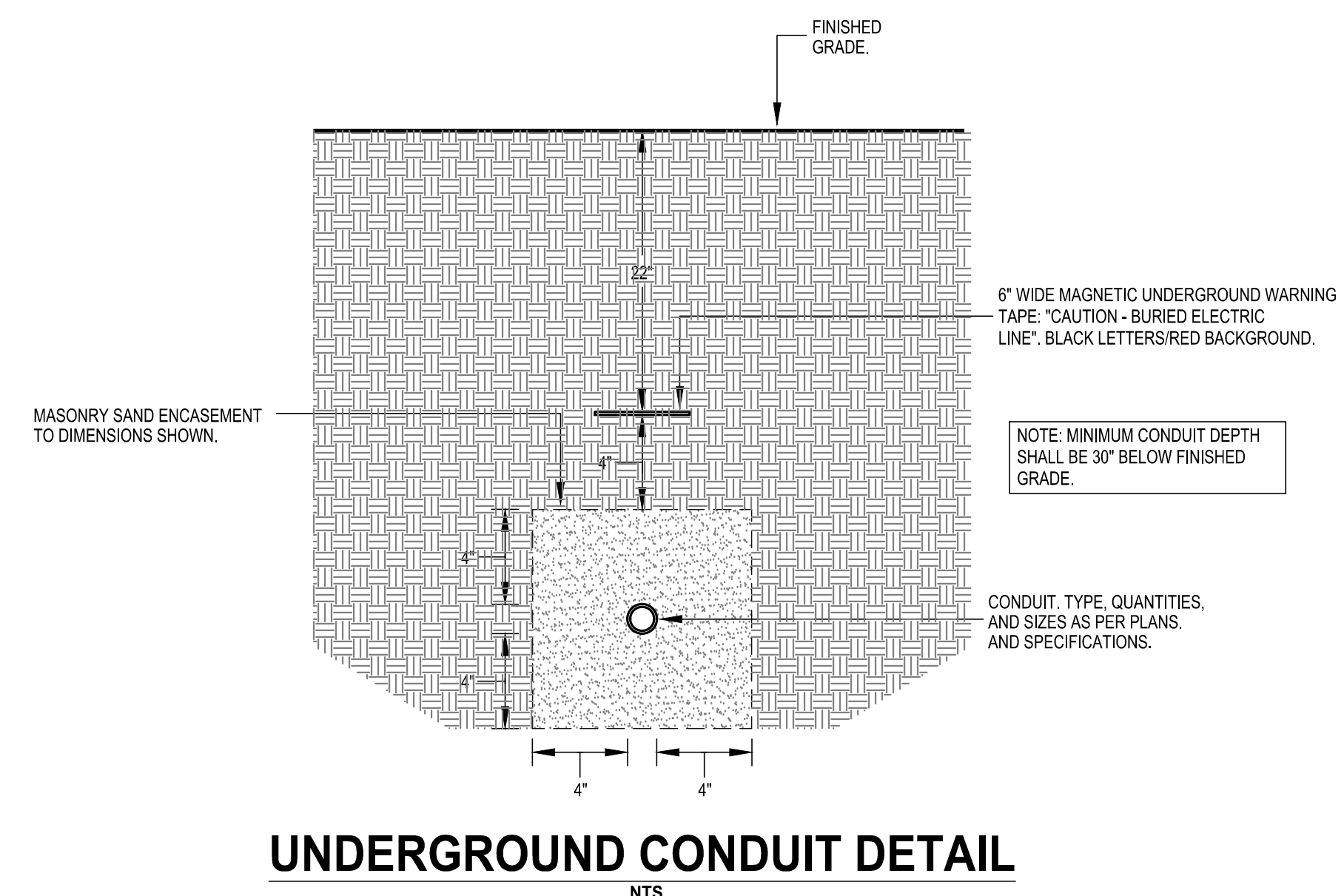
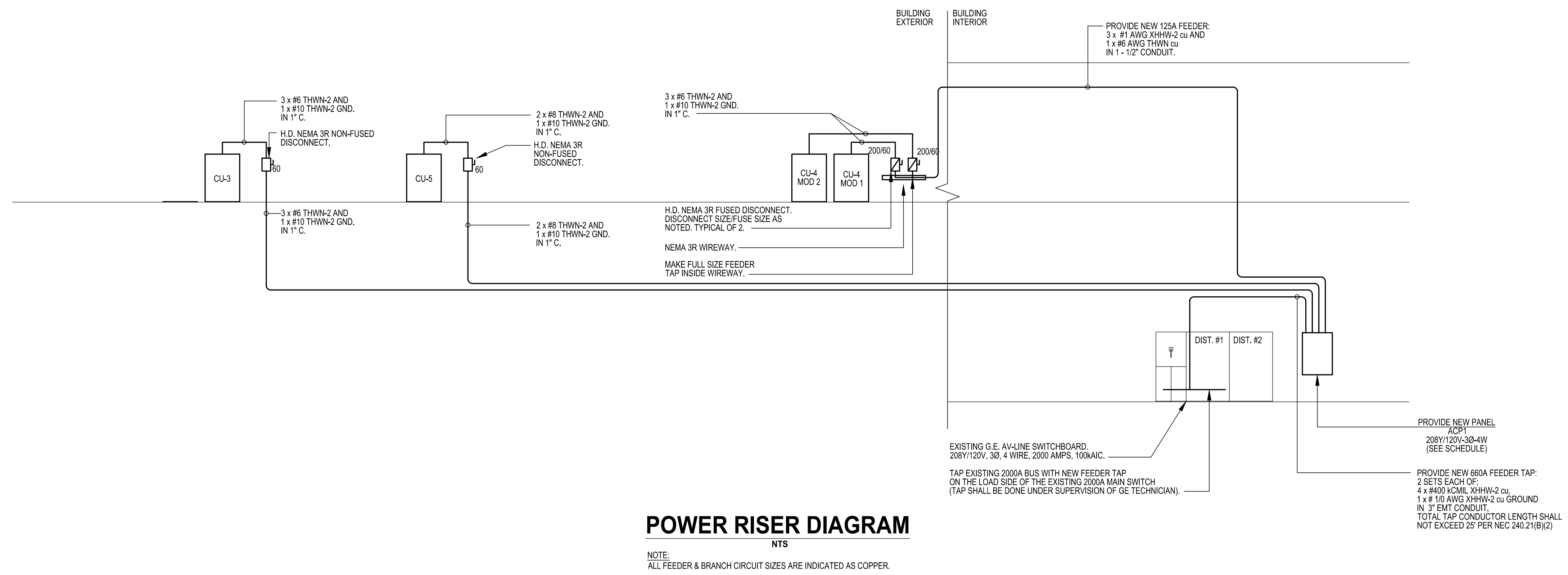

REVISIONS

ROGER SHERMAN ELEMENTARY SCHOOL
FIRST FLOOR NEW AIR CONDITIONING SYSTEM
 MERIDEN, CONNECTICUT

BEMIS ASSOCIATES, L.L.C.
 Consulting Engineers
 185 Main Street
 Farmington, CT 06032
 Fax: (860) 321-7070
 www.bemisassociates.com

BA

TITLE:
BASEMENT PART PLAN, SCHEDULES, RISERS & DETAILS

DATE: 05/30/2023

DWG. NO.
E1.0

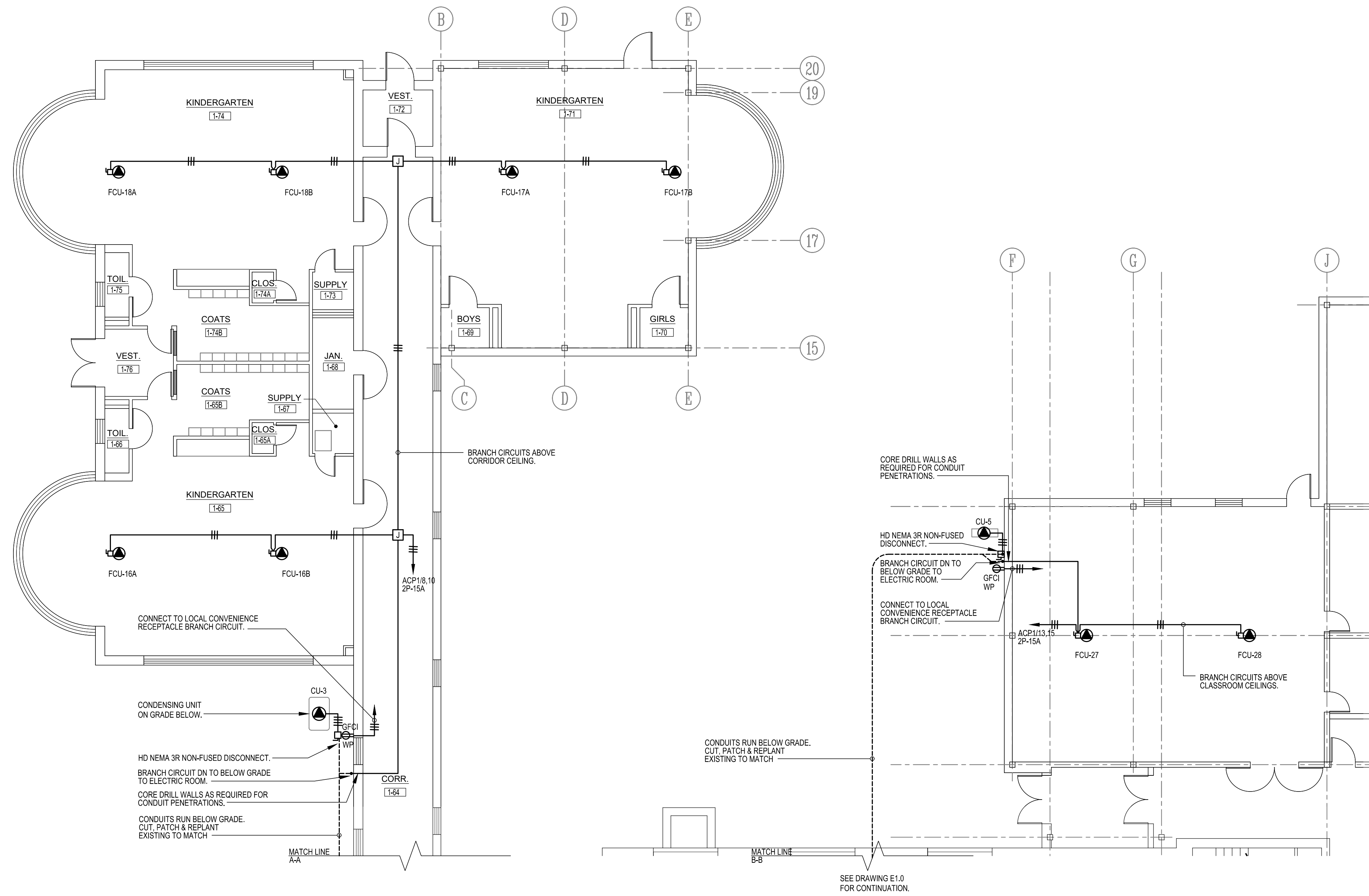

NORTHWEST FIRST FLOOR PART PLAN - ELECTRICAL
SCALE: 1/8"=1'-0"

ELECTRICAL DRAWING LEGEND	
SYMBOL/ABBREVIATION	DESCRIPTION
	EQUIPMENT POWER CONNECTION, EQUIPMENT TYPE AS DESIGNATED.
	NON-FUSED DISCONNECT SWITCH
	FUSED DISCONNECT SWITCH
	JUNCTION BOX WITH BLANK COVER PLATE.
	CONDUIT OR MC CABLE AS SPECIFIED
	CONDUIT BELOW GRADE
	BRANCH CIRCUIT WIRING, CROSS LINES INDICATE QUANTITY OF CONDUCTORS.
	BRANCH CIRCUIT WIRING HOMERUN, CROSS LINES INDICATE QUANTITY OF CONDUCTORS.
A	AMPS
C	CONDUIT
CB	CIRCUIT BREAKER
CU	CONDENSING UNIT
FCU	FAN COIL UNIT
GND	GROUND
HD	HEAVY-DUTY
P	POLE
UV	UNIT VENTILATOR
V	VOLTS

COPYRIGHT
This drawing is the property of BEIMS ASSOCIATES, L.L.C. and shall remain the property of BEIMS ASSOCIATES, L.L.C. No part of this drawing may be reproduced or transmitted in any form or by any means, electronic, mechanical, photocopying, recording, or by any information storage and retrieval system, without the prior written permission of BEIMS ASSOCIATES, L.L.C. All rights reserved. BEIMS ASSOCIATES, L.L.C. is not responsible for any errors or omissions in this drawing or for any consequences arising therefrom. Any adjustments or variations of this drawing shall be made by the client or the contractor and shall be approved by the architect or engineer of record.

ROGER SHERMAN ELEMENTARY SCHOOL
FIRST FLOOR NEW AIR CONDITIONING SYSTEM
MERIDEN, CONNECTICUT

BEIMS ASSOCIATES, L.L.C.
Consulting Engineers
185 Main Street
Farmington, CT 06032
Tel: (860) 321-7070
www.beimsassociates.com

TITLE
1ST FLOOR POWER PART PLANS

DATE 05/30/2023

DWG. NO.

E1.1

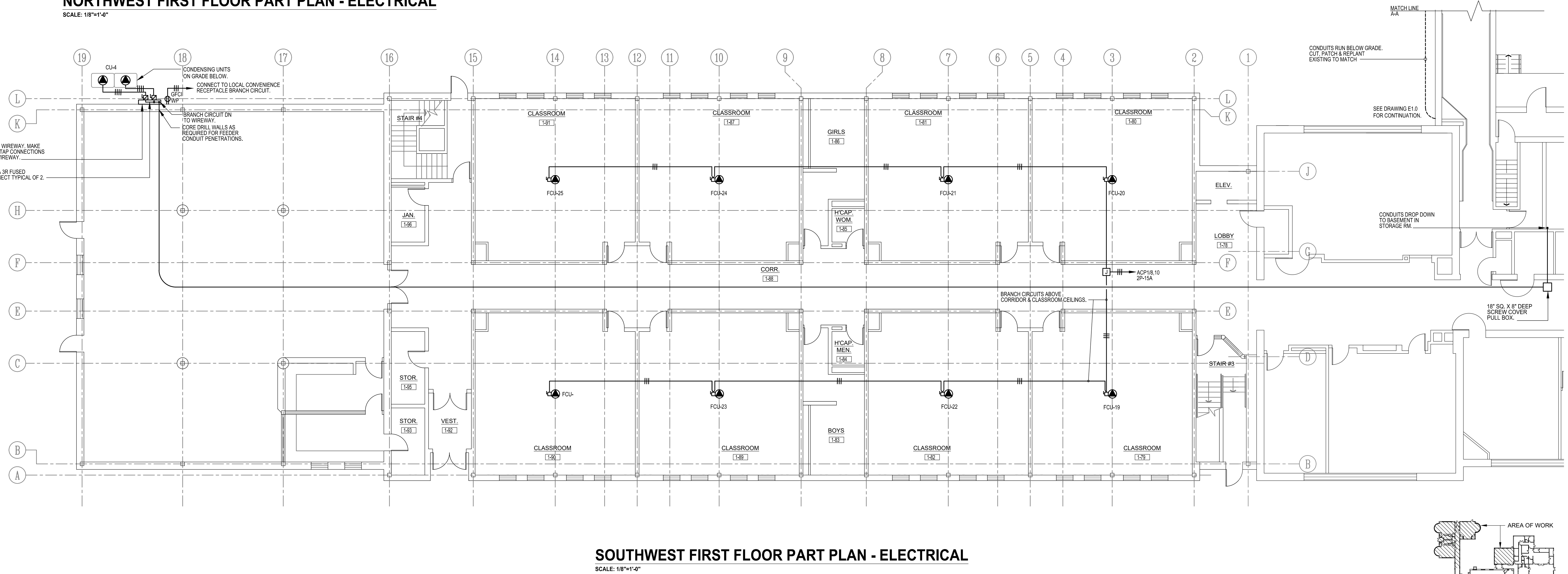

SOUTHWEST FIRST FLOOR PART PLAN - ELECTRICAL
SCALE: 1/8"=1'-0"

